



IIT KHARAGPUR



NPTEL ONLINE
CERTIFICATION COURSES

CLOUD COMPUTING

Cloud Computing - Overview

PROF. SOUMYA K. GHOSH

DEPARTMENT OF COMPUTER SCIENCE AND ENGINEERING
IIT KHARAGPUR

Introduction

- The *ACM Computing Curricula 2005* defined "computing" as

"In a general way, we can define computing to mean any goal-oriented activity requiring, benefiting from, or creating computers. Thus, computing includes designing and building hardware and software systems for a wide range of purposes; processing, structuring, and managing various kinds of information; doing scientific studies using computers; making computer systems behave intelligently; creating and using communications and entertainment media; finding and gathering information relevant to any particular purpose, and so on. The list is virtually endless, and the possibilities are vast."

Cloud Computing Course - Overview

- I. Introduction to Cloud Computing
 - i. Overview of Computing
 - ii. Cloud Computing (NIST Model)
 - iii. Properties, Characteristics & Disadvantages
 - iv. Role of Open Standards
- II. Cloud Computing Architecture
 - i. Cloud computing stack
 - ii. Service Models (XaaS)
 - a. Infrastructure as a Service(IaaS)
 - b. Platform as a Service(PaaS)
 - c. Software as a Service(SaaS)
 - iii. Deployment Models
- III. Service Management in Cloud Computing
 - i. Service Level Agreements(SLAs)
 - ii. Cloud Economics
- IV. Resource Management in Cloud Computing



Cloud Computing Course (contd.)

V. Data Management in Cloud Computing

- i. Looking at Data, Scalability & Cloud Services
- ii. Database & Data Stores in Cloud
- iii. Large Scale Data Processing

VI. Cloud Security

- i. Infrastructure Security
- ii. Data security and Storage
- iii. Identity and Access Management
- iv. Access Control, Trust, Reputation, Risk

VII. Case Study on Open Source and Commercial Clouds, Cloud Simulator

VIII. Research trend in Cloud Computing, Fog Computing



Trends in Computing

- Distributed Computing
- Grid Computing
- Cluster Computing
- Utility Computing
- **Cloud Computing**

Distributed Computing



Centralized vs. Distributed Computing

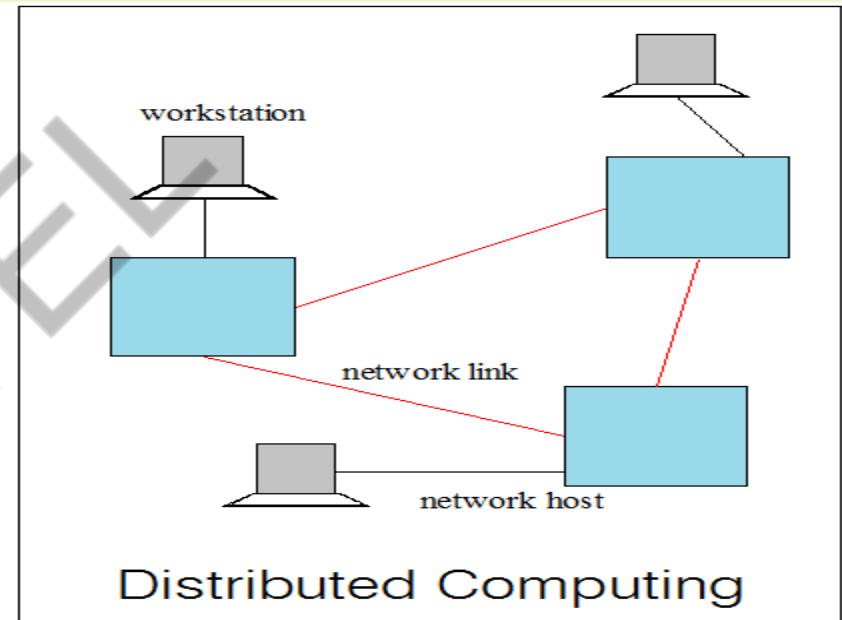
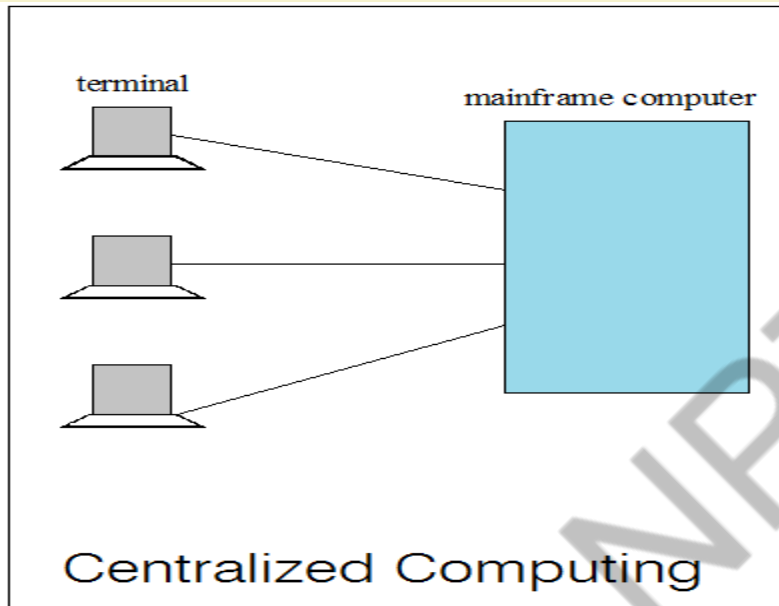

Early computing was performed on a single processor. Uni-processor computing can be called *centralized computing*.

Distributed Computing/System?

- Distributed computing
 - Field of computing science that studies distributed system.
 - Use of distributed systems to solve computational problems.
- Distributed system
 - Wikipedia
 - There are several autonomous computational entities, each of which has its own local memory.
 - The entities communicate with each other by message passing.
 - Operating System Concept
 - The processors communicate with one another through various communication lines, such as high-speed buses or telephone lines.
 - Each processor has its own local memory.

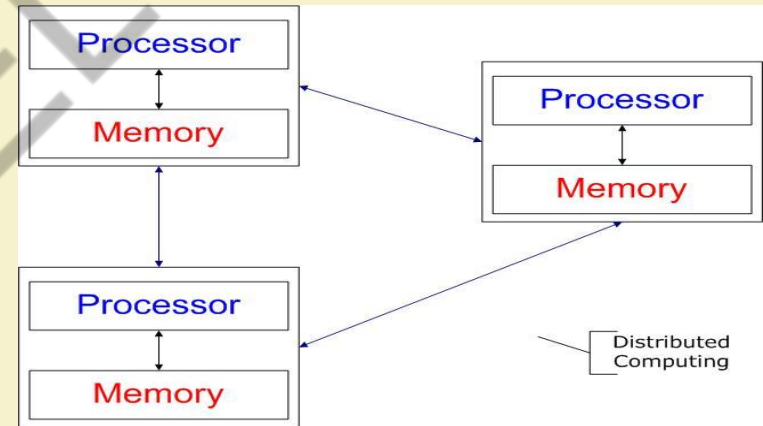

Example Distributed Systems

- Internet
- ATM (bank) machines
- Intranets/Workgroups
- Computing landscape will soon consist of ubiquitous network-connected devices

Computers in a Distributed System

- *Workstations*: Computers used by end-users to perform computing
- *Server Systems*: Computers which provide resources and services
- *Personal Assistance Devices*: Handheld computers connected to the system via a wireless communication link.



Common properties of Distributed Computing

- Fault tolerance
 - When one or some nodes fails, the whole system can still work fine except performance.
 - Need to check the status of each node
- Each node play partial role
 - Each computer has only a limited, incomplete view of the system.
 - Each computer may know only one part of the input.
- Resource sharing
 - Each user can share the computing power and storage resource in the system with other users
- Load Sharing
 - Dispatching several tasks to each nodes can help share loading to the whole system.
- Easy to expand
 - We expect to use few time when adding nodes. Hope to spend no time if possible.
- Performance
 - Parallel computing can be considered a subset of distributed computing

Why Distributed Computing?

- Nature of application
- Performance
 - Computing intensive
 - The task could consume a lot of time on computing. For example, Computation of Pi value using Monte Carlo simulation
 - Data intensive
 - The task that deals with a large amount or large size of files. For example, Facebook, LHC(Large Hadron Collider) experimental data processing.
- Robustness
 - No SPOF (Single Point Of Failure)
 - Other nodes can execute the same task executed on failed node.

Thank You!!





IIT KHARAGPUR



NPTEL ONLINE
CERTIFICATION COURSES

CLOUD COMPUTING

CLOUD COMPUTING OVERVIEW (contd..)

PROF. SOUMYA K. GHOSH

DEPARTMENT OF COMPUTER SCIENCE AND ENGINEERING
IIT KHARAGPUR

Why Distributed Computing?

- Nature of application
- Performance
 - Computing intensive
 - The task could consume a lot of time on computing. For example, Computation of Pi value using Monte Carlo simulation
 - Data intensive
 - The task that deals with a large amount or large size of files. For example, Facebook, LHC(Large Hadron Collider) experimental data processing.
- Robustness
 - No SPOF (Single Point Of Failure)
 - Other nodes can execute the same task executed on failed node.

Distributed applications

- Applications that consist of a set of processes that are distributed across a network of machines and work together as an ensemble to solve a common problem
- In the past, mostly “client-server”
 - Resource management centralized at the server
- “Peer to Peer” computing represents a movement towards more “truly” distributed applications

Clients invoke individual servers

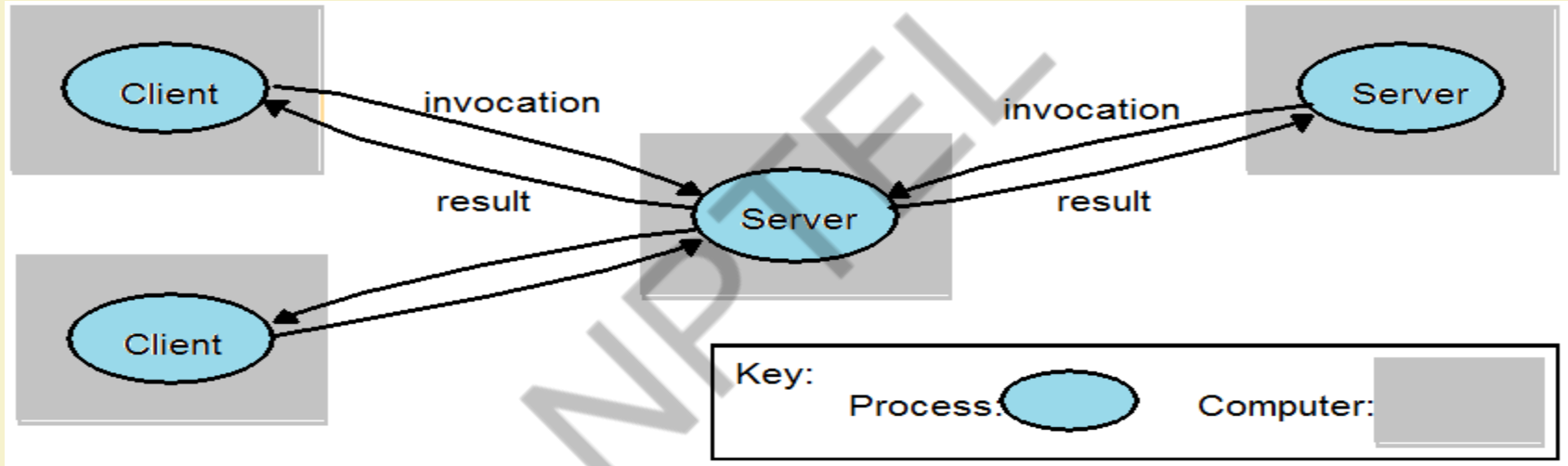

A typical distributed application based on peer processes

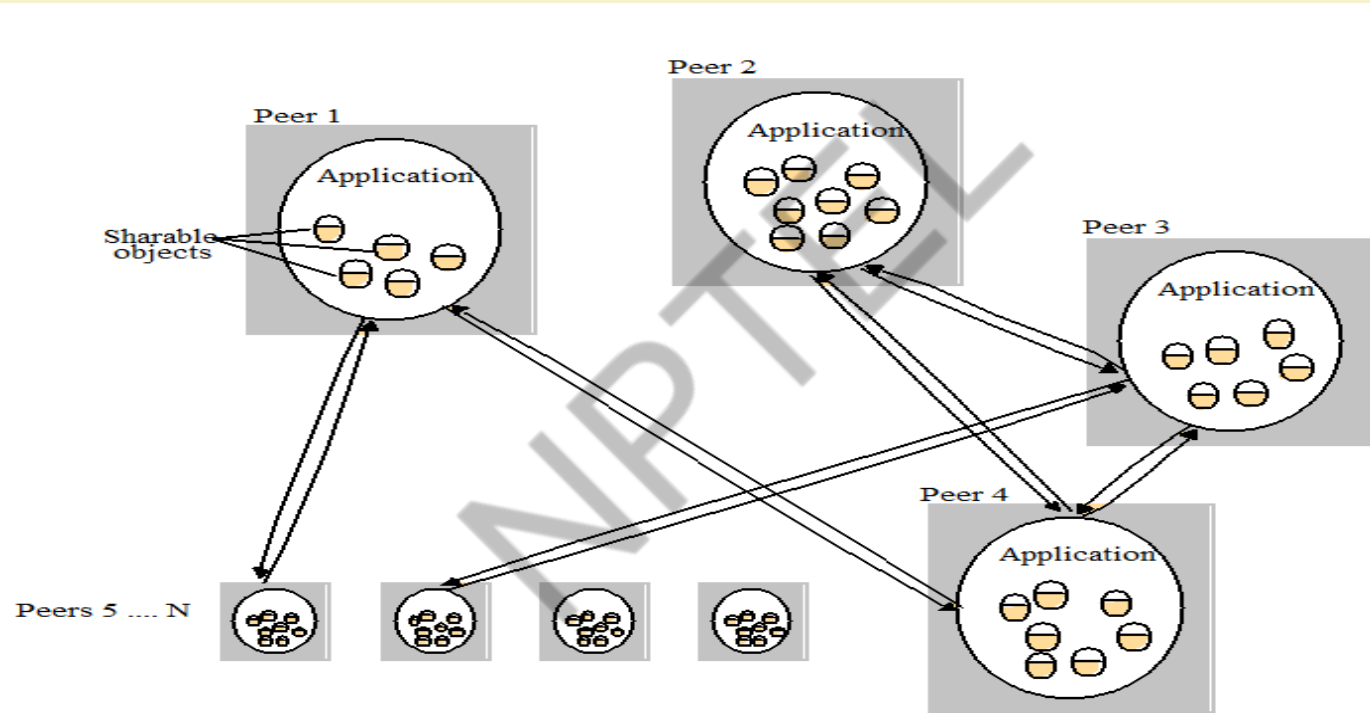

Grid Computing



Grid Computing?

- Pcwebopedia.com
 - A form of networking. unlike conventional networks that focus on communication among devices, grid computing harnesses unused processing cycles of all computers in a network for solving problems too intensive for any stand-alone machine.
- IBM
 - Grid computing enables the virtualization of distributed computing and data resources such as processing, network bandwidth and storage capacity to create a single system image, granting users and applications seamless access to vast IT capabilities. Just as an Internet user views a unified instance of content via the Web, a grid user essentially sees a single, large virtual computer.
- Sun Microsystems
 - Grid Computing is a computing infrastructure that provides dependable, consistent, pervasive and inexpensive access to computational capabilities

Electrical Power Grid Analogy

Electrical Power Grid

- Users (or electrical appliances) get access to electricity through wall sockets with no care or consideration for where or how the electricity is actually generated.
- **“The power grid”** links together power plants of many different kinds

Grid

- Users (or client applications) gain access to computing resources (processors, storage, data, applications, and so on) as needed with little or no knowledge of where those resources are located or what the underlying technologies, hardware, operating system, and so on are
- **“The Grid”** links together computing resources (PCs, workstations, servers, storage elements) and provides the mechanism needed to access them.

Grid Computing

When v use

1. Share more than information: Data, computing power, applications in dynamic environment, multi-institutional, virtual organizations
2. Efficient use of resources at many institutes. People from many institutions working to solve a common problem (virtual organisation).
3. Join local communities.
4. Interactions with the underneath layers must be transparent and seamless to the user.

Need of Grid Computing?

- Today's Science/Research is based on computations, data analysis, data visualization & collaborations
- Computer Simulations & Modelling are more cost effective than experimental methods **Mathematical modeling of systems**
- Scientific and Engineering problems are becoming more complex & users need more accurate, precise solutions to their problems in shortest possible time
- Data Visualization is becoming very important
- Exploiting under utilized resources

Who uses Grid Computing ?

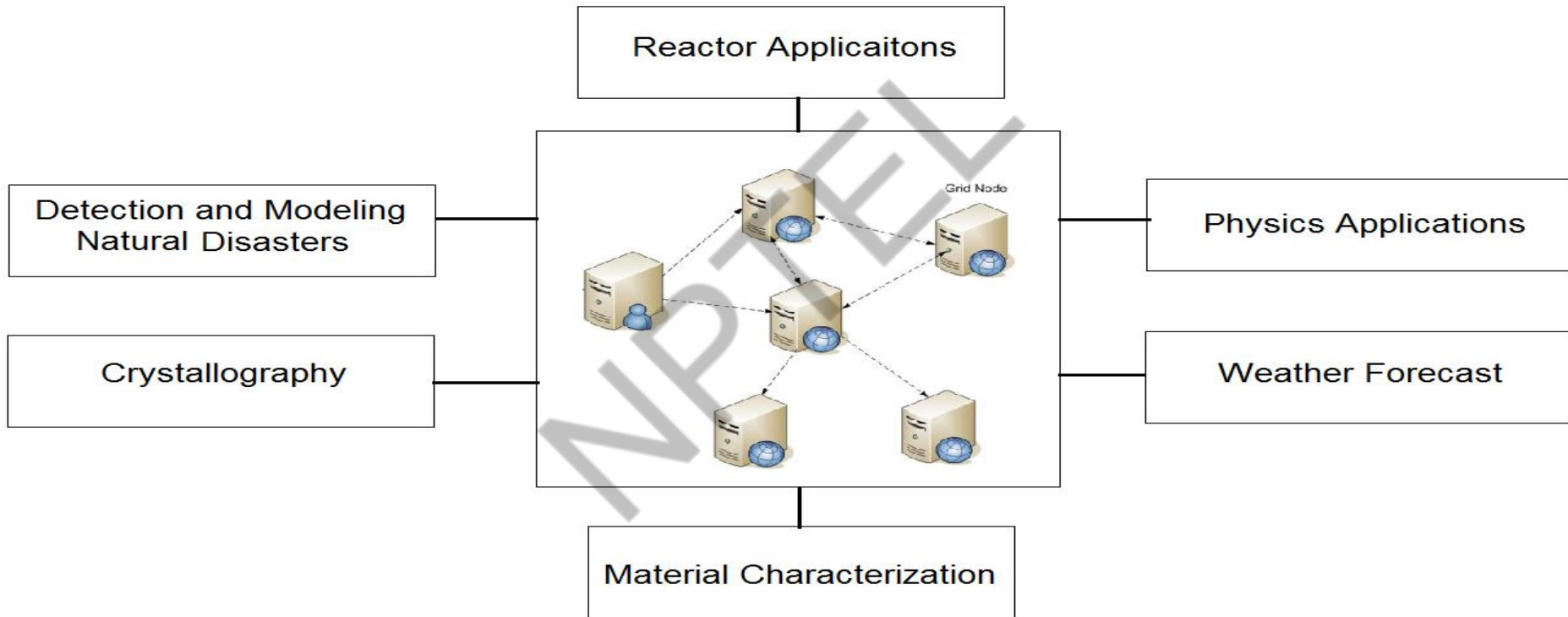

Type of Grids

- **Computational Grid:** These grids provide secure access to huge pool of shared processing power suitable for high throughput applications and computation intensive computing.
- **Data Grid:** Data grids provide an infrastructure to support data storage, data discovery, data handling, data publication, and data manipulation of large volumes of data actually stored in various heterogeneous databases and file systems.
- **Collaboration Grid:** With the advent of Internet, there has been an increased demand for better collaboration. Such advanced collaboration is possible using the grid. For instance, persons from different companies in a virtual enterprise can work on different components of a CAD project without even disclosing their proprietary technologies.

Type of Grids

- **Network Grid:** A Network Grid provides fault-tolerant and high-performance communication services. Each grid node works as a data router between two communication points, providing data-caching and other facilities to speed up the communications between such points.
- **Utility Grid:** This is the ultimate form of the Grid, in which not only data and computation cycles are shared but software or just about any resource is shared. The main services provided through utility grids are software and special equipment. For instance, the applications can be run on one machine and all the users can send their data to be processed to that machine and receive the result back.

Grid Components

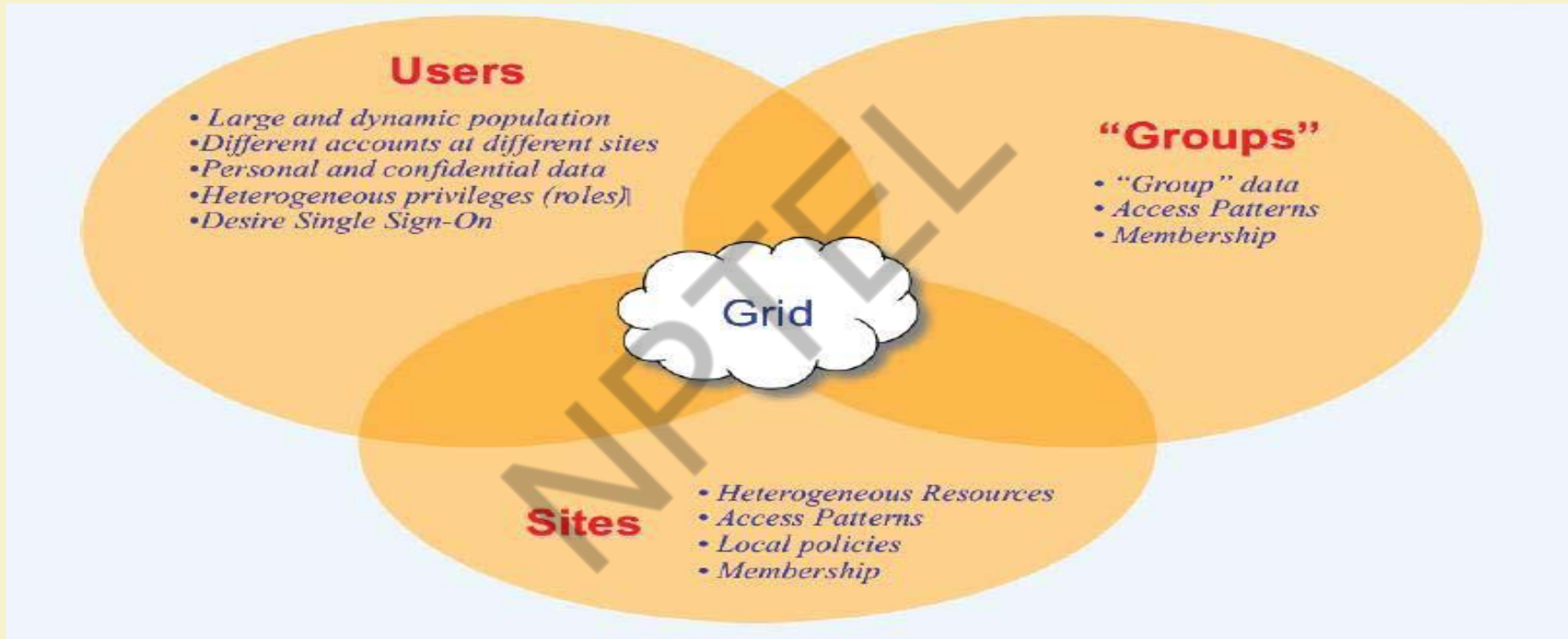

Cluster Computing



What is Cluster Computing?

- A cluster is a type of parallel or distributed computer system, which consists of a collection of inter-connected stand-alone computers working together as a single integrated computing resource .
- Key components of a cluster include multiple standalone computers (PCs, Workstations, or SMPs), operating systems, high-performance interconnects, middleware, parallel programming environments, and applications.

Cluster Computing?

- Clusters are usually deployed to improve speed and/or reliability over that provided by a single computer, while typically being much more cost effective than single computer the of comparable speed or reliability
- In a typical cluster:
 - Network: Faster, closer connection than a typical network (LAN)
 - Low latency communication protocols
 - Loosely coupled than SMP



Types of Cluster

- High Availability or Failover Clusters
- Load Balancing Cluster
- Parallel/Distributed Processing Clusters



Cluster Components

- Basic building blocks of clusters are broken down into multiple categories:
 - **Cluster Nodes**
 - **Cluster Network**
 - **Network Characterization**

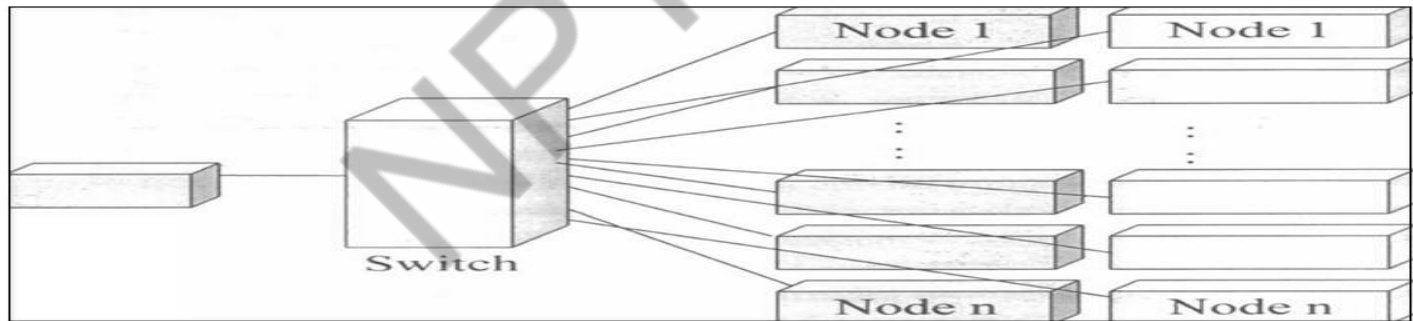

Key Operational Benefits of Clustering

- System availability: offer inherent high system availability due to the redundancy of hardware, operating systems, and applications.
- Hardware fault tolerance: redundancy for most system components (eg. disk-RAID), including both hardware and software.
- OS and application reliability: run multiple copies of the OS and applications, and through this redundancy
- Scalability. adding servers to the cluster or by adding more clusters to the network as the need arises or CPU to SMP.
- High performance: (running cluster enabled programs)



Utility Computing



“Utility” Computing ?

- Utility Computing is purely a concept which cloud computing practically implements.
- Utility computing is a service provisioning model in which a service provider makes computing resources and infrastructure management available to the customer as needed, and charges them for specific usage rather than a flat rate.
- This model has the advantage of a low or no initial cost to acquire computer resources; instead, computational resources are essentially rented.
- The word *utility* is used to make an analogy to other services, such as electrical power, that seek to meet fluctuating customer needs, and charge for the resources based on usage rather than on a flat-rate basis. This approach, sometimes known as *pay-per-use*



“Utility” Computing ?

- "Utility computing" has usually envisioned some form of virtualization so that the amount of storage or computing power available is considerably larger than that of a single time-sharing computer.

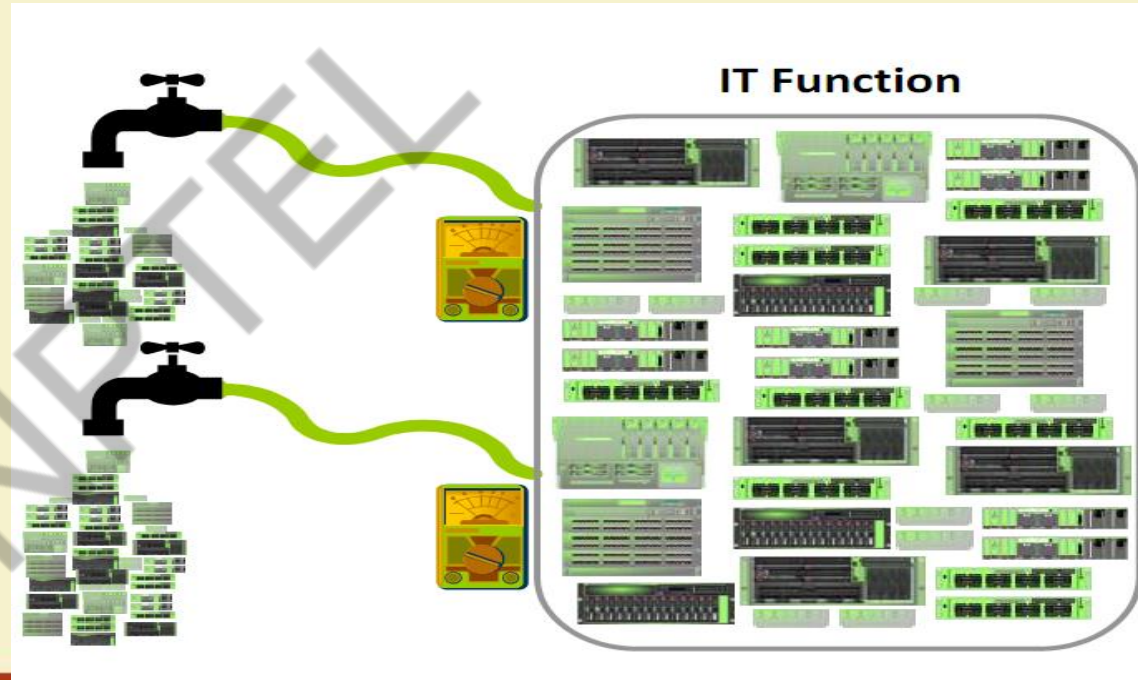

“Utility” Computing ?

- a) Pay-for-use Pricing **Business Model**
- b) Data Center Virtualization and **Provisioning**
- c) Solves **Resource Utilization** Problem
- d) **Outsourcing**
- e) **Web Services Delivery**
- f) Automation



Utility Computing Example

On-Demand Cyber Infrastructure

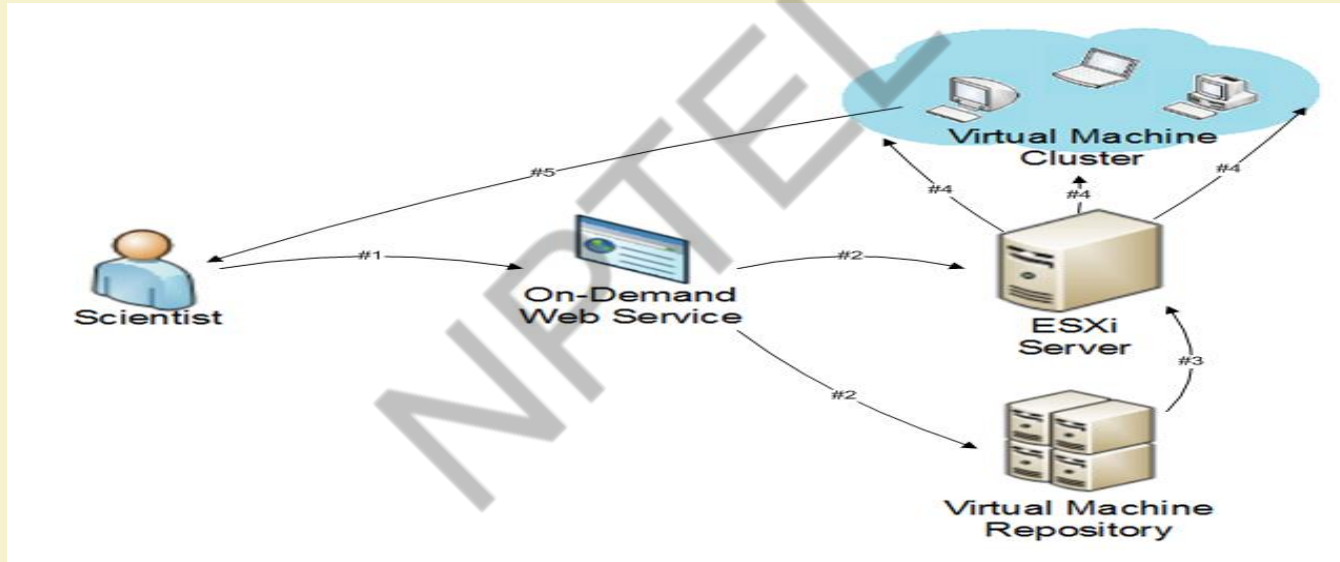

Utility Solution – Your Perspective

Consumer vs Provider

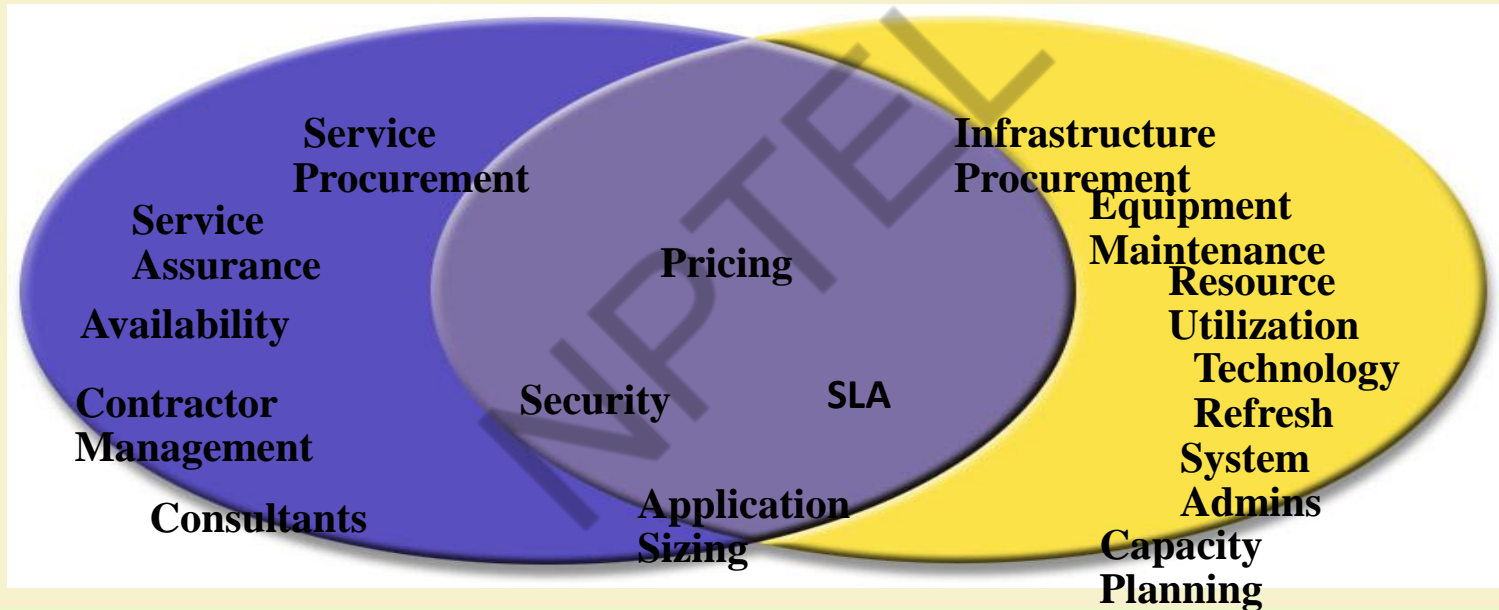

Source: Perry Boster, "Utility Computing for Shared Services",
Massachusetts Digital Government Summit, September 23rd, 2004 –
Boston, MA

Utility Computing Payment Models

- Same range of charging models as other utility providers: gas, electricity, telecommunications, water, television broadcasting
 - Flat rate
 - Tiered
 - Subscription
 - Metered
 - Pay as you go
 - Standing charges
- Different pricing models for different customers based on factors such as scale, commitment and payment frequency
- But the principle of utility computing remains
- The pricing model is simply an expression by the provider of the costs of provision of the resources and a profit margin

Risks in a UC World

- Data Backup
- Data Security
- Partner Competency
- Defining SLA
- Getting value from charge back

Cloud Computing



Cloud Computing

US National Institute of Standards and Technology defines Computing as

“ Cloud computing is a model for enabling ubiquitous, convenient, on-demand network access to a shared pool of configurable computing resources (e.g networks, servers, storage, applications, and services) that can be rapidly provisioned and released with minimal management effort or service provider interaction. ”

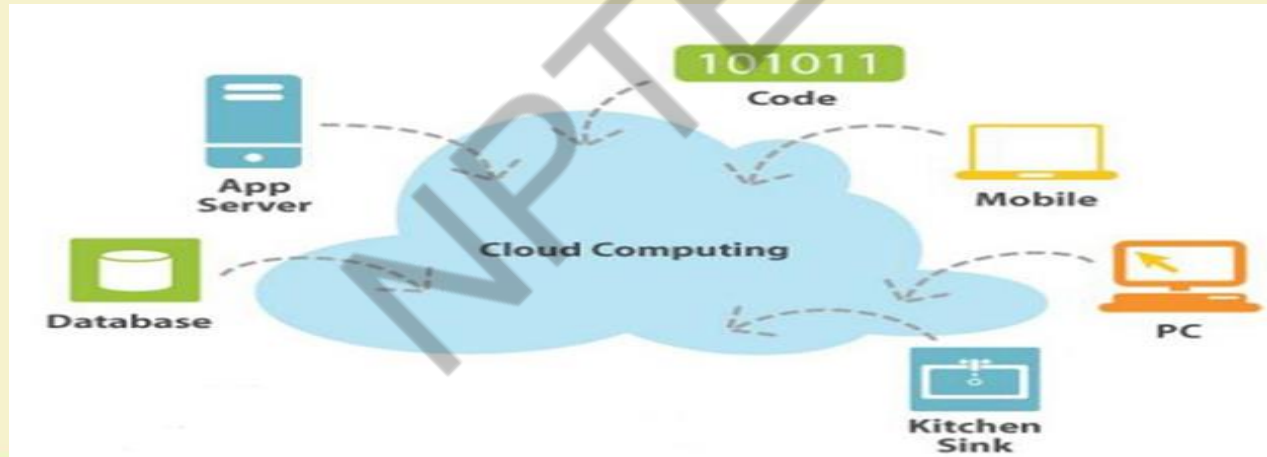

Thank You!!





IIT KHARAGPUR



NPTEL ONLINE
CERTIFICATION COURSES

Cloud Computing - Overview

Prof. Soumya K Ghosh

Department of Computer Science and Engineering

IIT KHARAGPUR

Cloud Computing



Cloud Computing

US National Institute of Standards and Technology (NIST) defines Computing as:

“ Cloud computing is a model for enabling ubiquitous, convenient, on-demand network access to a shared pool of configurable computing resources (e.g. networks, servers, storage, applications, and services) that can be rapidly provisioned and released with minimal management effort or service provider interaction. ”

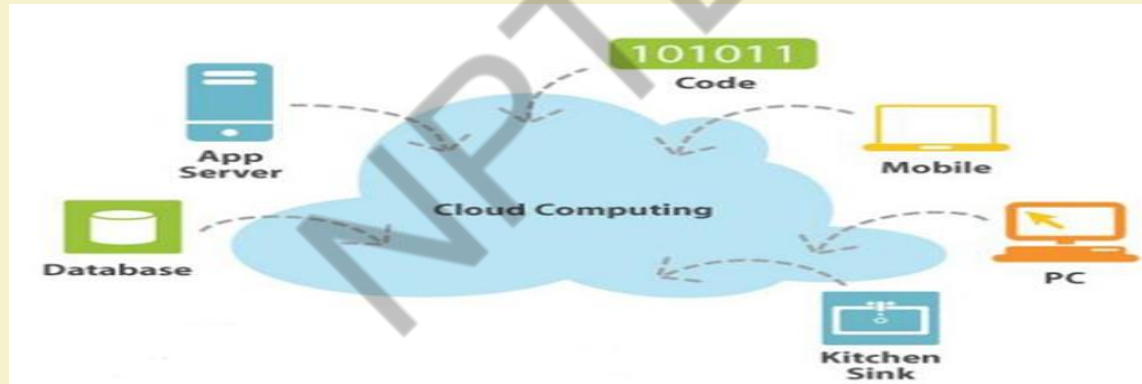

<http://www.smallbiztechnology.com/archive/2011/09/wait-what-is-cloud-computing.html>

Essential Characteristics

- **On-demand self-service**
 - A consumer can unilaterally provision computing capabilities, such as server time and network storage, as needed automatically without requiring human interaction with each service provider.
- **Broad network access**
 - Capabilities are available over the network and accessed through standard mechanisms that promote use by heterogeneous thin or thick client platforms (e.g., mobile phones, tablets, laptops, and workstations).
- **Resource pooling**
 - The provider's computing resources are pooled to serve multiple consumers using a multi-tenant model, with different physical and virtual resources dynamically assigned and reassigned according to consumer demand.

Cloud Characteristics

Measured Service

- Cloud systems automatically control and optimize resource use by leveraging a metering capability at some level of abstraction appropriate to the type of service (e.g., storage, processing, bandwidth, and active user accounts). Resource usage can be
- monitored, controlled, and reported, providing transparency for both the provider and consumer of the utilized service.
- **Rapid elasticity**
 - Capabilities can be elastically provisioned and released, in some cases automatically, to scale rapidly outward and inward commensurate with demand. To the consumer, the capabilities available for provisioning often appear to be unlimited and can be appropriated in any quantity at any time.



Common Characteristics

- Massive Scale
- Resilient Computing
- Homogeneity
- Geographic Distribution
- Virtualization
- Service Orientation
- Low Cost Software
- Advanced Security

Cloud Services Models

- **Software as a Service (SaaS)**

- The capability provided to the consumer is to use the provider's applications running on a cloud infrastructure. The applications are accessible from various client devices through either a thin client interface, such as a web browser (e.g., web-based email), or a program interface.
- The consumer does not manage or control the underlying cloud infrastructure including network, servers, operating systems, storage, or even individual application capabilities, with the possible exception of limited user-specific application configuration settings.
- e.g: *Google Spread Sheet*

- **Cloud Infrastructure as a Service (IaaS)**

- The capability provided to provision processing, storage, networks, and other fundamental computing resources
- Consumer can deploy and run arbitrary software
- e.g: *Amazon Web Services and Flexi scale.*

Cloud Services Models

Platform as a Service (PaaS)

- The capability provided to the consumer is to deploy onto the cloud infrastructure consumer-created or acquired applications created using programming languages, libraries, services, and tools supported by the provider.
- The consumer does not manage or control the underlying cloud infrastructure including network, servers, operating systems, or storage, but has control over the deployed applications and possibly configuration settings for the application-hosting environment.

Cloud Services Models

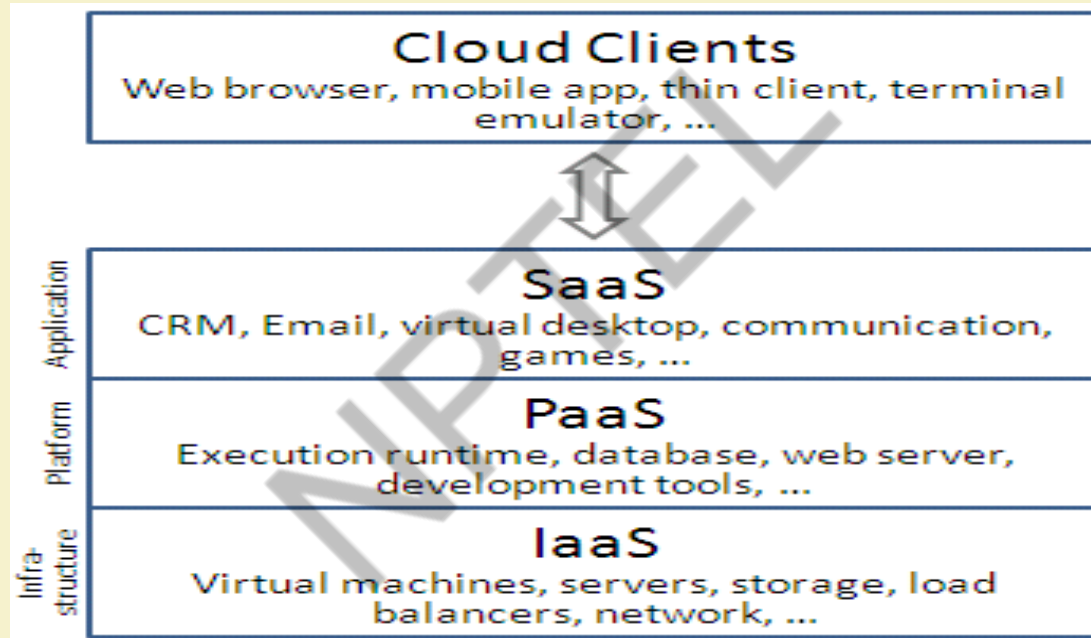

Types of Cloud (Deployment Models)

- **Private cloud**

The cloud infrastructure is operated solely for an organization.

e.g Window Server 'Hyper-V'.

- **Community cloud**

The cloud infrastructure is shared by several organizations and supports a specific goal.

- **Public cloud**

The cloud infrastructure is made available to the general public

e.g Google Doc, Spreadsheet,

- **Hybrid cloud**

The cloud infrastructure is a composition of two or more clouds (private, community, or public)

e.g Cloud Bursting for load balancing between clouds.

Cloud and Virtualization

- **Virtual Workspaces:**

- An abstraction of an execution environment that can be made dynamically available to authorized clients by using well-defined protocols,
- Resource quota (e.g. CPU, memory share),
- Software configuration (e.g. OS).

- **Implement on Virtual Machines (VMs):**

- Abstraction of a physical host machine,
- Hypervisor intercepts and emulates instructions from VMs, and allows management of VMs,
- VMWare, Xen, KVM etc.

- **Provide infrastructure API:**

- Plug-ins to hardware/support structures

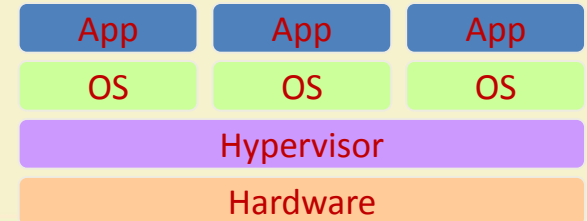

Virtual Machines

- VM technology allows multiple virtual machines to run on a single physical machine.

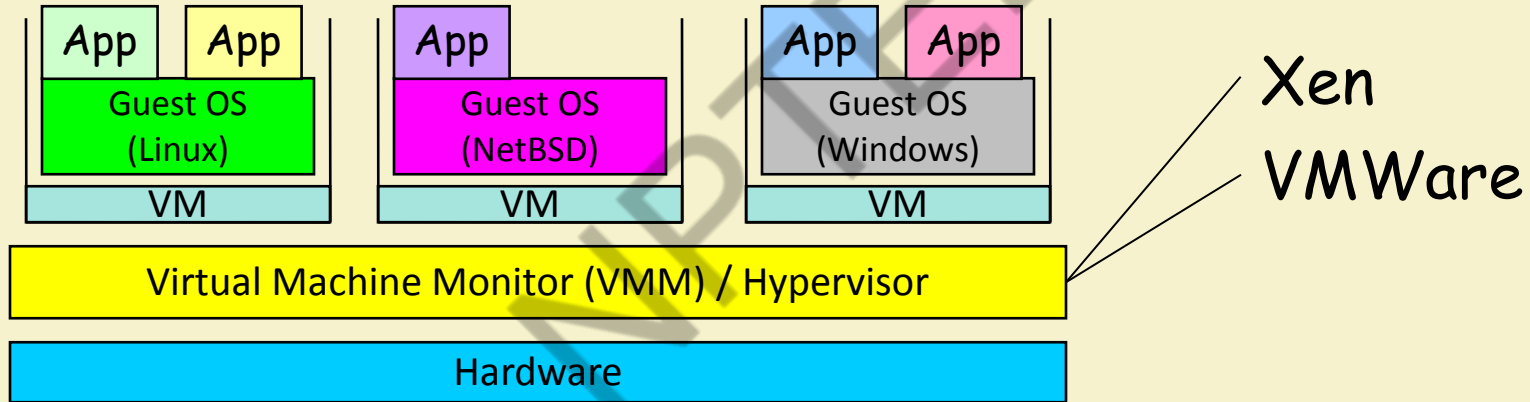

- Performance: Para-virtualization (e.g. Xen) is very close to raw physical performance!

Virtualization in General

- *Advantages of virtual machines:*
 - Run operating systems where the physical hardware is unavailable,
 - Easier to create new machines, backup machines, etc.,
 - Software testing using “clean” installs of operating systems and software,
 - Emulate more machines than are physically available,
 - Timeshare lightly loaded systems on one host,
 - Debug problems (suspend and resume the problem machine),
 - Easy migration of virtual machines (shutdown needed or not).
 - Run legacy systems

Cloud-Sourcing

- **Why is it becoming important ?**
 - Using high-scale/low-cost providers,
 - Any time/place access via web browser,
 - Rapid scalability; incremental cost and load sharing,
 - Can forget need to focus on local IT.
- **Concerns:**
 - Performance, reliability, and SLAs,
 - Control of data, and service parameters,
 - Application features and choices,
 - Interaction between Cloud providers,
 - No standard API – mix of SOAP and REST!
 - Privacy, security, compliance, trust...

Cloud Storage

- Several large Web companies are now exploiting the fact that they have data storage capacity that can be hired out to others.
 - Allows data stored remotely to be temporarily cached on desktop computers, mobile phones or other Internet-linked devices.
- Amazon's Elastic Compute Cloud (EC2) and Simple Storage Solution (S3) are well known examples

Advantages of Cloud Computing

- **Lower computer costs:**
 - No need of a high-powered and high-priced computer to run cloud computing's web-based applications.
 - Since applications run in the cloud, not on the desktop PC, your desktop PC does not need the processing power or hard disk space demanded by traditional desktop software.
 - When you are using web-based applications, your PC can be less expensive, with a smaller hard disk, less memory, more efficient processor...
 - In fact, your PC in this scenario does not even need a CD or DVD drive, as no software programs have to be loaded and no document files need to be saved.

Advantages of Cloud Computing

- **Improved performance:**
 - With few large programs hogging your computer's memory, you will see better performance from your PC.
 - Computers in a cloud computing system boot and run faster because they have fewer programs and processes loaded into memory.
- **Reduced software costs:**
 - Instead of purchasing expensive software applications, you can get most of what you need for free.
 - most cloud computing applications today, such as the Google Docs suite.
 - better than paying for similar commercial software
 - which alone may be justification for switching to cloud applications.

Advantages of Cloud Computing

- **Instant software updates**
 - Another advantage to cloud computing is that you are no longer faced with choosing between obsolete software and high upgrade costs.
 - When the application is web-based, updates happen automatically available the next time you log into the cloud.
 - When you access a web-based application, you get the latest version without needing to pay for or download an upgrade.
- **Improved document format compatibility.**
 - You do not have to worry about the documents you create on your machine being compatible with other users' applications or OS.
 - There are less format incompatibilities when everyone is sharing documents and applications in the cloud.

Advantages of Cloud Computing

- **Unlimited storage capacity**
 - Cloud computing offers virtually limitless storage.
 - Your computer's current 1 Tera Bytes hard drive is small compared to the hundreds of Peta Bytes available in the cloud.
- **Increased data reliability**
 - Unlike desktop computing, in which if a hard disk crashes and destroy all your valuable data, a computer crashing in the cloud should not affect the storage of your data.
 - if your personal computer crashes, all your data is still out there in the cloud, still accessible
 - In a world where few individual desktop PC users back up their data on a regular basis, cloud computing is a data-safe computing platform. For e.g. Dropbox, Skydrive

Advantages of Cloud Computing

- **Universal information access**
 - That is not a problem with cloud computing, because you do not take your documents with you.
 - Instead, they stay in the cloud, and you can access them whenever you have a computer and an Internet connection
 - Documents are instantly available from wherever you are.
- **Latest version availability**
 - When you edit a document at home, that edited version is what you see when you access the document at work.
 - The cloud always hosts the latest version of your documents as long as you are connected, you are not in danger of having an outdated version.

Advantages of Cloud Computing

- **Easier group collaboration**
 - Sharing documents leads directly to better collaboration.
 - Many users do this as it is an important advantages of cloud computing multiple users can collaborate easily on documents and projects
- **Device independence**
 - You are no longer tethered to a single computer or network.
 - Changes to computers, applications and documents follow you through the cloud.
 - Move to a portable device, and your applications and documents are still available.

Disadvantages of Cloud Computing

- **Requires a constant internet connection**
 - Cloud computing is impossible if you cannot connect to the Internet.
 - Since you use the Internet to connect to both your applications and documents, if you do not have an Internet connection you cannot access anything, even your own documents.
 - A dead Internet connection means no work and in areas where Internet connections are few or inherently unreliable, this could be a deal-breaker.
- **Does not work well with low-speed connections**
 - Similarly, a low-speed Internet connection, such as that found with dial-up services, makes cloud computing painful at best and often impossible.
 - Web-based applications require a lot of bandwidth to download, as do large documents.

Disadvantages of Cloud Computing

- **Features might be limited**
 - This situation is bound to change, but today many web-based applications simply are not as full-featured as their desktop-based applications.
 - For example, you can do a lot more with Microsoft PowerPoint than with Google Presentation's web-based offering
- **Can be slow**
 - Even with a fast connection, web-based applications can sometimes be slower than accessing a similar software program on your desktop PC.
 - Everything about the program, from the interface to the current document, has to be sent back and forth from your computer to the computers in the cloud.
 - If the cloud servers happen to be backed up at that moment, or if the Internet is having a slow day, you would not get the instantaneous access you might expect from desktop applications.

Disadvantages of Cloud Computing

- **Stored data might not be secured**
 - With cloud computing, all your data is stored on the cloud.
 - The questions is How secure is the cloud?
 - Can unauthorized users gain access to your confidential data ?
- **Stored data can be lost!**
 - Theoretically, data stored in the cloud is safe, replicated across multiple machines.
 - But on the off chance that your data goes missing, you have no physical or local backup.
 - Put simply, relying on the cloud puts you at risk if the cloud lets you down.

Disadvantages of Cloud Computing

- **HPC Systems** High performance system
 - Not clear that you can run compute-intensive HPC applications that use MPI/OpenMP!
 - Scheduling is important with this type of application
 - as you want all the VM to be co-located to minimize communication latency!
- **General Concerns**
 - Each cloud systems uses different protocols and different APIs
 - may not be possible to run applications between cloud based systems
 - Amazon has created its own DB system (not SQL 92), and workflow system (many popular workflow systems out there)
 - so your normal applications will have to be adapted to execute on these platforms.

Evolution of Cloud Computing

Business drivers for adopting cloud computing



Reasons

- The main reason for interest in cloud computing is due to the fact that public clouds can significantly reduce IT costs.
- From an end user perspective cloud computing gives the illusion of potentially infinite capacity with ability to scale rapidly and pay only for the consumed resource.
- In contrast, provisioning for peak capacity is a necessity within private data centers, leading to a low average utilization of 5-20 percent.

IaaS Economics

	In house server	Cloud server
Purchase Cost	\$9600 (x86,3QuadCore,12GB RAM, 300GB HD)	0
Cost/hr (over 3 years)	\$0.36	\$0.68
Cost ratio: Cloud/In house	1.88	
Efficiency	40%	80%
Cost/Effective hr	\$0.90	\$0.85
Power and cooling	\$0.36	0
Management Cost	\$0.10	\$0.01
Total cost/effective hr	\$1.36	\$0.86
Cost ratio: In house/Cloud	1.58	

Benefits for the end user while using public cloud

- High utilization
- High scalability
- No separate hardware procurement
- No separate power cost
- No separate IT infrastructure administration/maintenance required
- Public clouds offer user friendly SLA by offering high availability (~99%) and also provide compensation in case of SLA miss.
- Users can rent the cloud to develop and test prototypes before making major investments in technology

Benefits for the end user while using public cloud

- In order to enhance portability from one public cloud to another, several organizations such as Cloud Computing Interoperability Forum and Open Cloud Consortium are coming up with standards for portability.
- For e.g. Amazon EC2 and Eucalyptus share the same API interface.
- Software startups benefit tremendously by renting computing and storage infrastructure on the cloud instead of buying them as they are uncertain about their own future.

Benefits for Small and Medium Businesses (<250 employees)

SMBs & Cloud Services

Tasks in cloud services currently and in 2-3 years

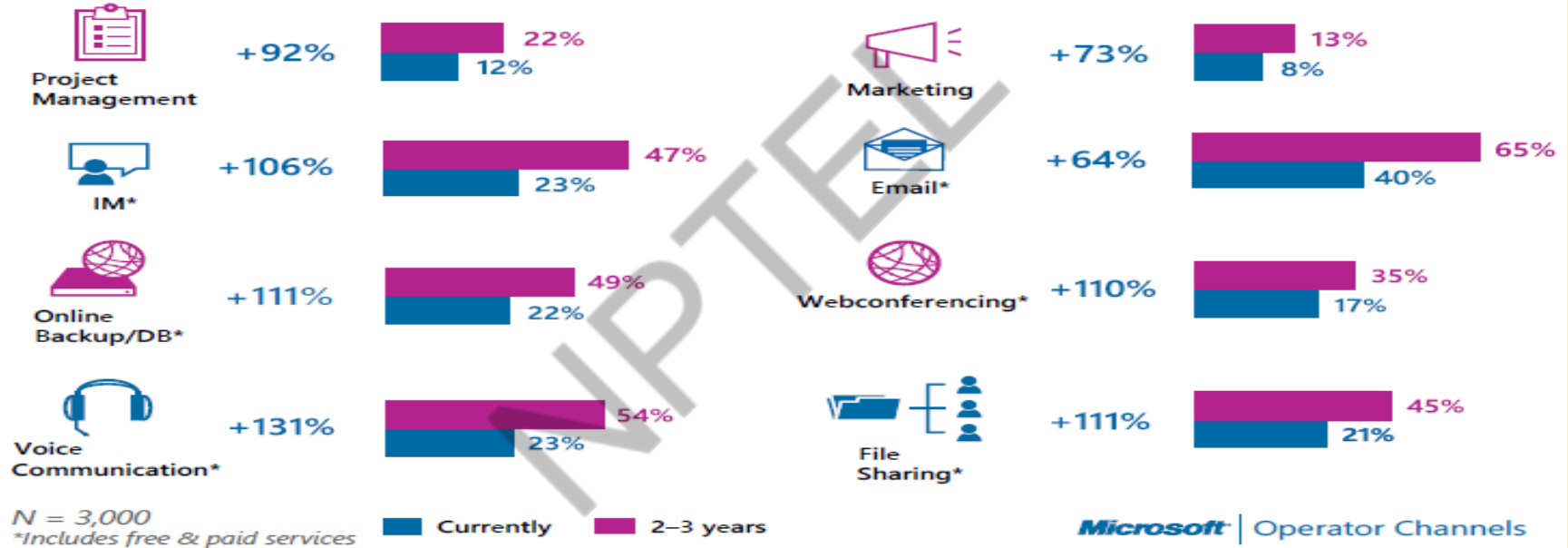

Source: <http://www.microsoft.com/en-us/news/presskits/telecom/docs/SMBCloud.pdf>

Benefits of private cloud

- Cost of 1 server with 12 cores and 12 GB RAM is far lower than the cost of 12 servers having 1 core and 1 GB RAM.
- Confidentiality of data is preserved
- Virtual machines are cheaper than actual machines
- Virtual machines are faster to provision than actual machines



Economics of PaaS vs IaaS

- Consider a web application that needs to be available 24X7, but where the transaction volume is unpredictable and can vary rapidly
- Using an IaaS cloud, a minimal number of servers would need to be provisioned at all times to ensure availability
- In contrast, merely deploying the application on PaaS cloud costs nothing. Depending upon the usage, costs are incurred.
- The PaaS cloud scales automatically to successfully handle increased requests to the web application.

Source: Enterprise Cloud Computing by Gautam Shroff

PaaS benefits

- No need for the user to handle scaling and load balancing of requests among virtual machines
- PaaS clouds also provide web based Integrated Development Environment for development and deployment of application on the PaaS cloud.
- Easier to migrate code from development environment to the actual production environment.
- Hence developers can directly write applications on the cloud and don't have to buy separate licenses of IDE.

SaaS benefits

- Users subscribe to web services and web applications instead of buying and licensing software instances.
- For e.g. Google Docs can be used for free, instead of buying document reading softwares such as Microsoft Word.
- Enterprises can use web based SaaS Content Relationship Management applications, instead of buying servers and installing CRM softwares and associated databases on them.

Customer relationship management



Benefits, as perceived by the IT industry

Q: Rate the **benefits** commonly ascribed to the 'cloud'/on-demand model
(1=not important, 5=very important)

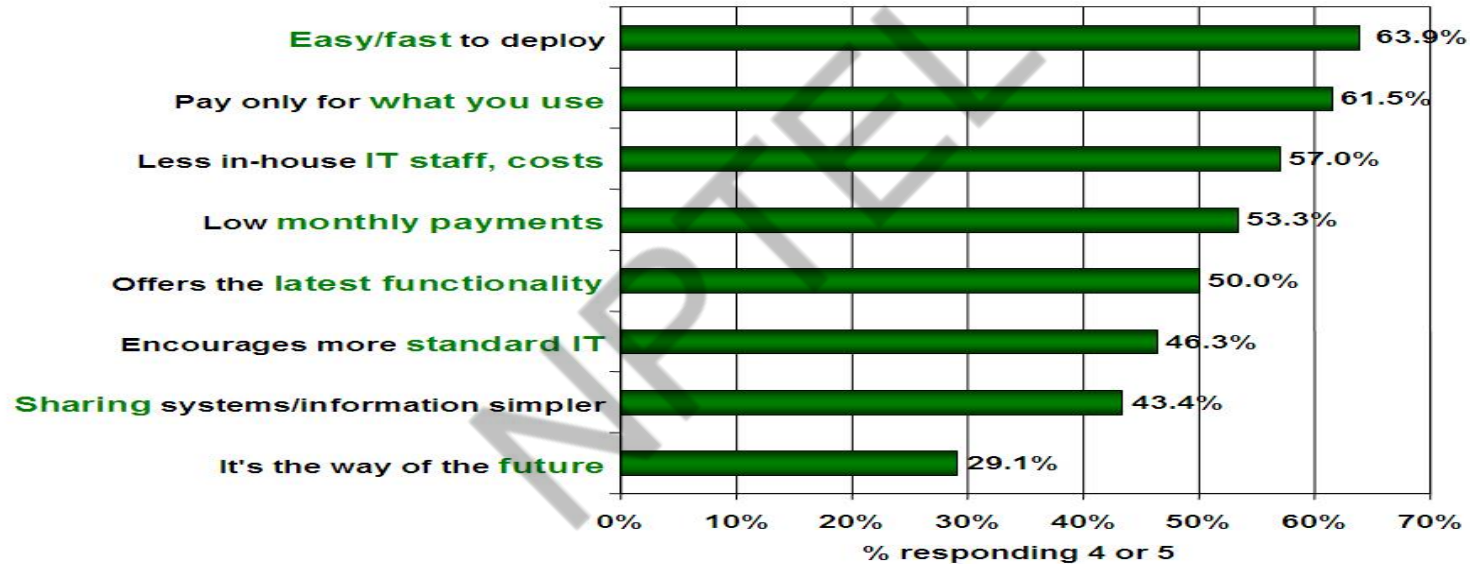

Source: IDC Enterprise Panel, August 2008 n=244



Factors driving investment in cloud

Factors driving investments in cloud per business size

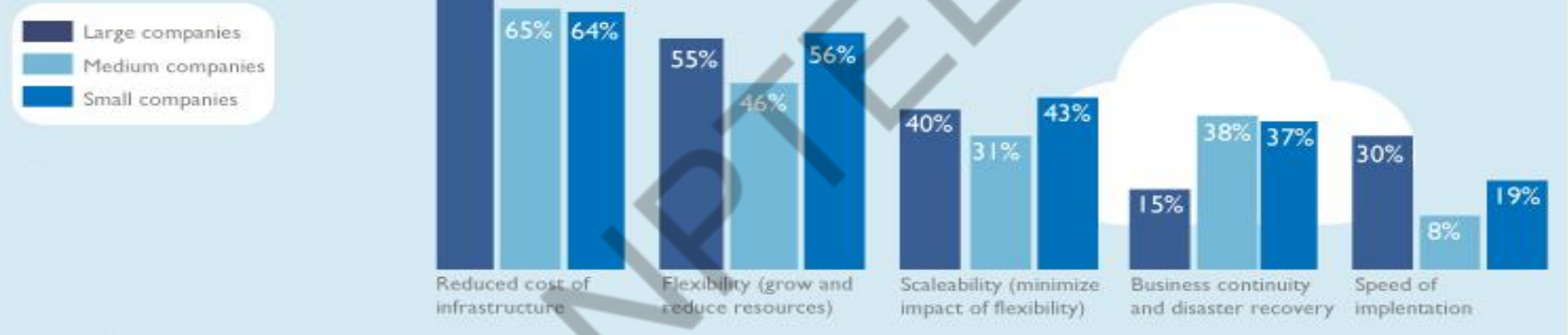

Source: <http://www.cloudtweaks.com/2012/01/infographic-whats-driving-investment-in-cloud-computing/>

Factors driving investment in cloud

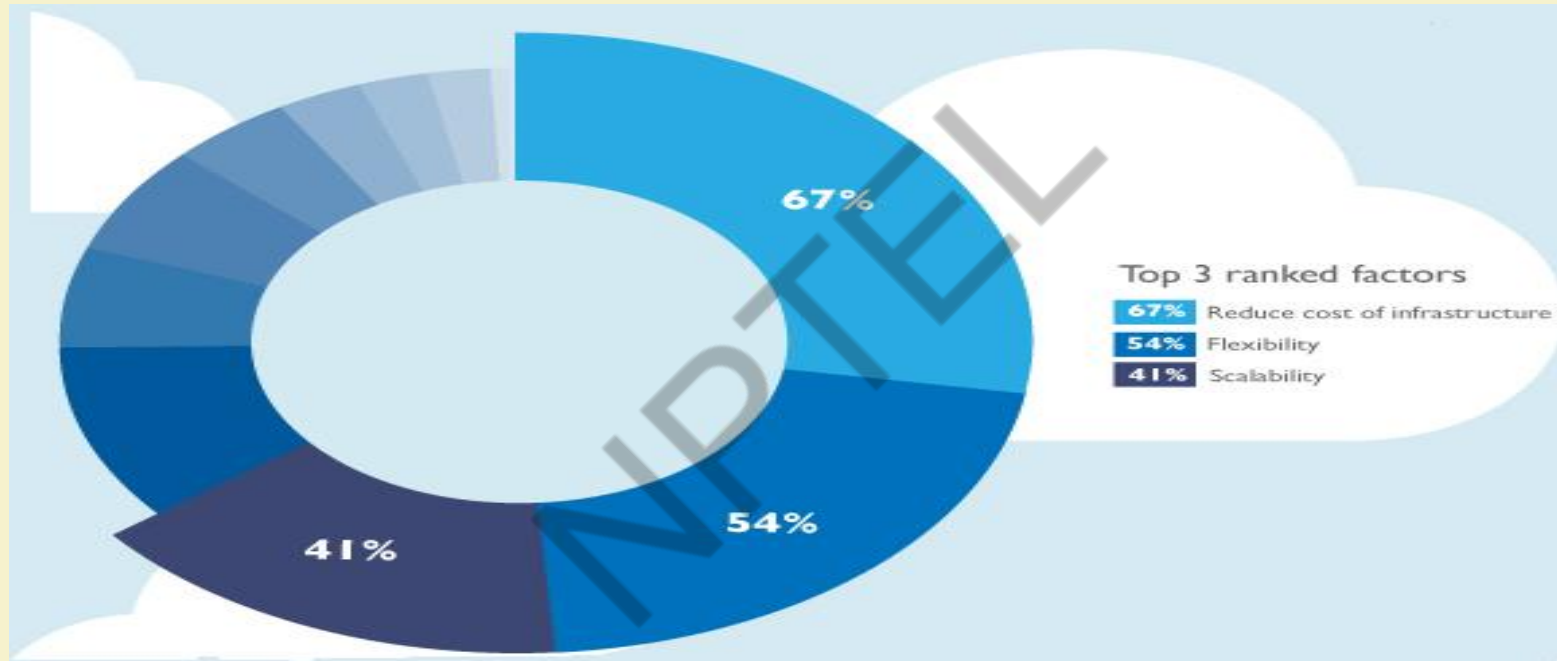

Source: <http://www.cloudtweaks.com/2012/01/infographic-whats-driving-investment-in-cloud-computing/>

Purpose of cloud computing in organizations

- Providing an IT platform for business processes involving multiple organizations
- Backing up data **Enterprise resource planning**
- Running CRM, ERP, or supply chain management applications
- Providing personal productivity and collaboration tools to employees
- Developing and testing software
- Storing and archiving large files (e.g., video or audio)
- Analyzing customer or operations data
- Running e-business or e-government web sites

Source: <http://askvisory.com/research/key-drivers-of-cloud-computing-activity/>

Purpose of cloud computing in organizations

- Analyzing data for research and development
- Meeting spikes in demand on our web site or internal systems
- Processing and storing applications or other forms
- Running data-intensive batch applications (e.g., data conversion, risk modeling, graphics rendering)
- Sharing information with the government or regulators
- Providing consumer entertainment, information and communication (e.g., music, video, photos, social networks)

Put an end

Source: <http://askvisory.com/research/key-drivers-of-cloud-computing-activity/>

Top cloud applications that are driving cloud adaptation

- Mail and Messaging
- Archiving
- Backup
- Storage
- Security
- Virtual Servers
- CRM (Customer Relationship Management)
- Collaboration across enterprises
- Hosted PBX (Private Branch Exchange)
- Video Conferencing

Source: <http://www.itnewsafrika.com/2012/09/ten-drivers-of-cloud-computing-for-south-african-businesses/>

Thank You!





IIT KHARAGPUR



NPTEL ONLINE
CERTIFICATION COURSES

CLOUD COMPUTING

CLOUD COMPUTING ARCHITECTURE

PROF. SOUMYA K. GHOSH

DEPARTMENT OF COMPUTER SCIENCE AND ENGINEERING
IIT KHARAGPUR

Context: High Level Architectural Approach

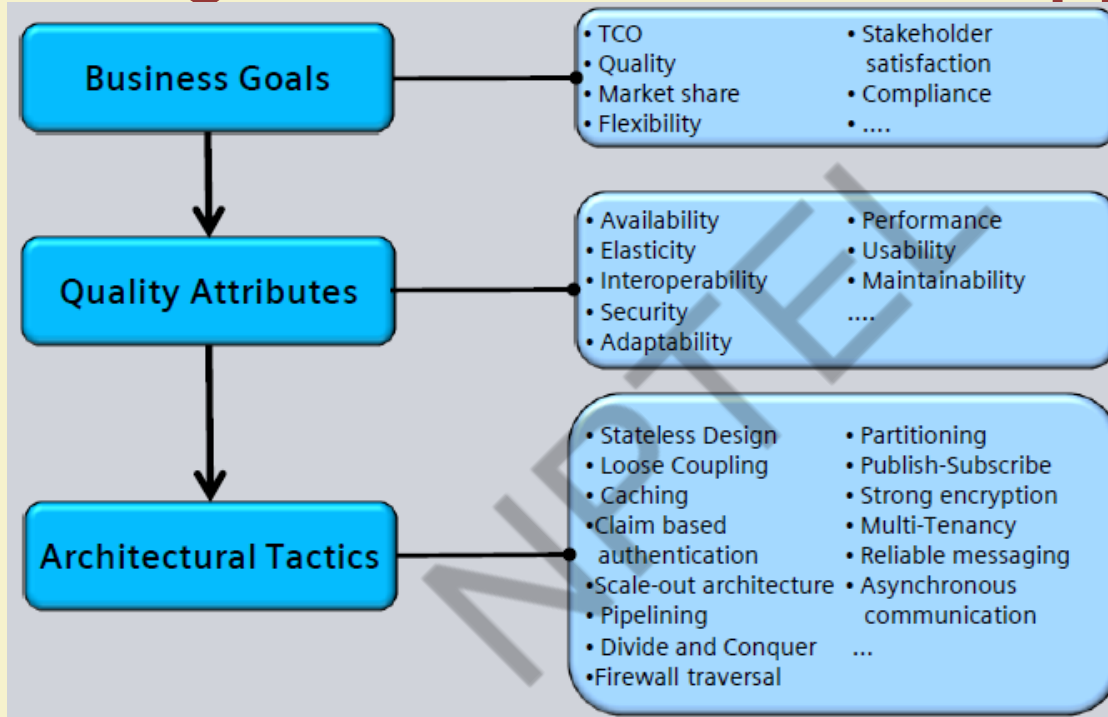

Source: <http://www.sei.cmu.edu/library/assets/presentations/Cloud%20Computing%20Architecture%20-%20Gerald%20Kaefer.pdf>

Major building blocks of Cloud Computing Architecture

- **Technical Architecture:**
 - Structuring according to XaaS stack
 - Adopting cloud computing paradigms
 - Structuring cloud services and cloud components
 - Showing relationships and external endpoints
 - Middleware and communication
 - Management and security
- **Deployment Operation Architecture:**
 - Geo-location check (Legal issues, export control)
 - Operation and Monitoring

Ref: <http://www.sei.cmu.edu/library/assets/presentations/Cloud%20Computing%20Architecture%20-%20Gerald%20Kafer.pdf>

Cloud Computing Architecture - XaaS



Source: <http://www.sei.cmu.edu/library/assets/presentations/Cloud%20Computing%20Architecture%20-%20Gerald%20Kaefer.pdf>

XaaS Stack views: Customer view vs Provider view

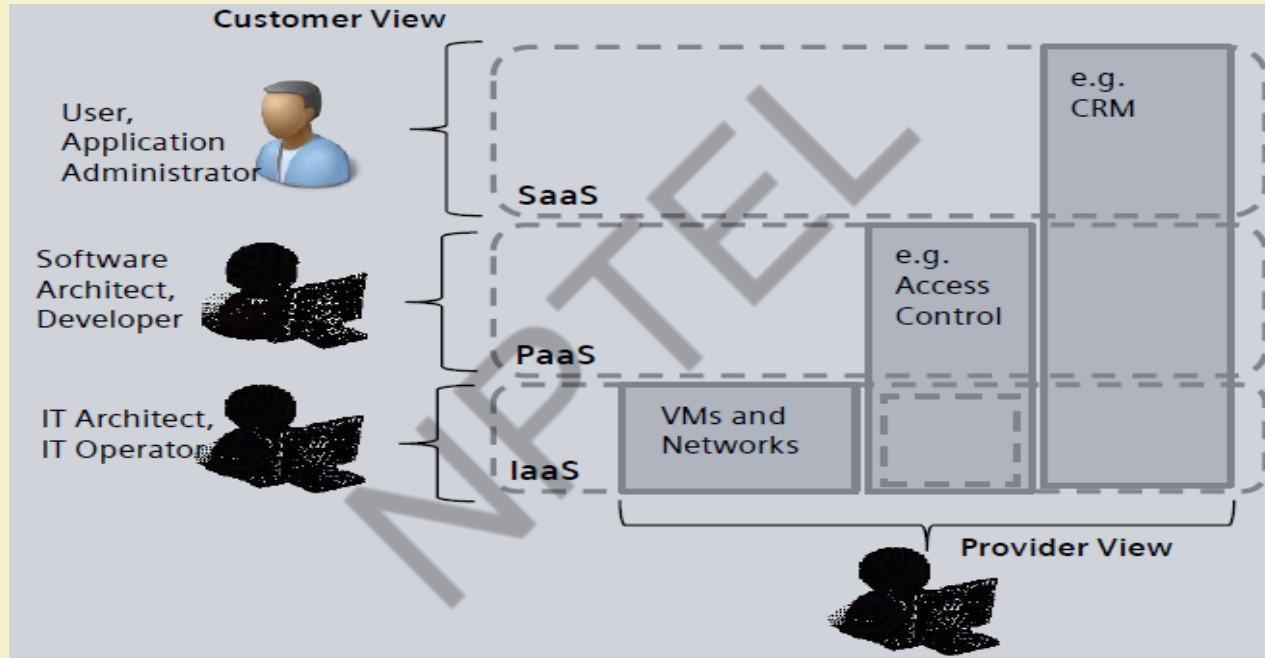

Source: <http://www.sei.cmu.edu/library/assets/presentations/Cloud%20Computing%20Architecture%20-%20Gerald%20Kaefer.pdf>

Microsoft Azure vs Amazon EC2

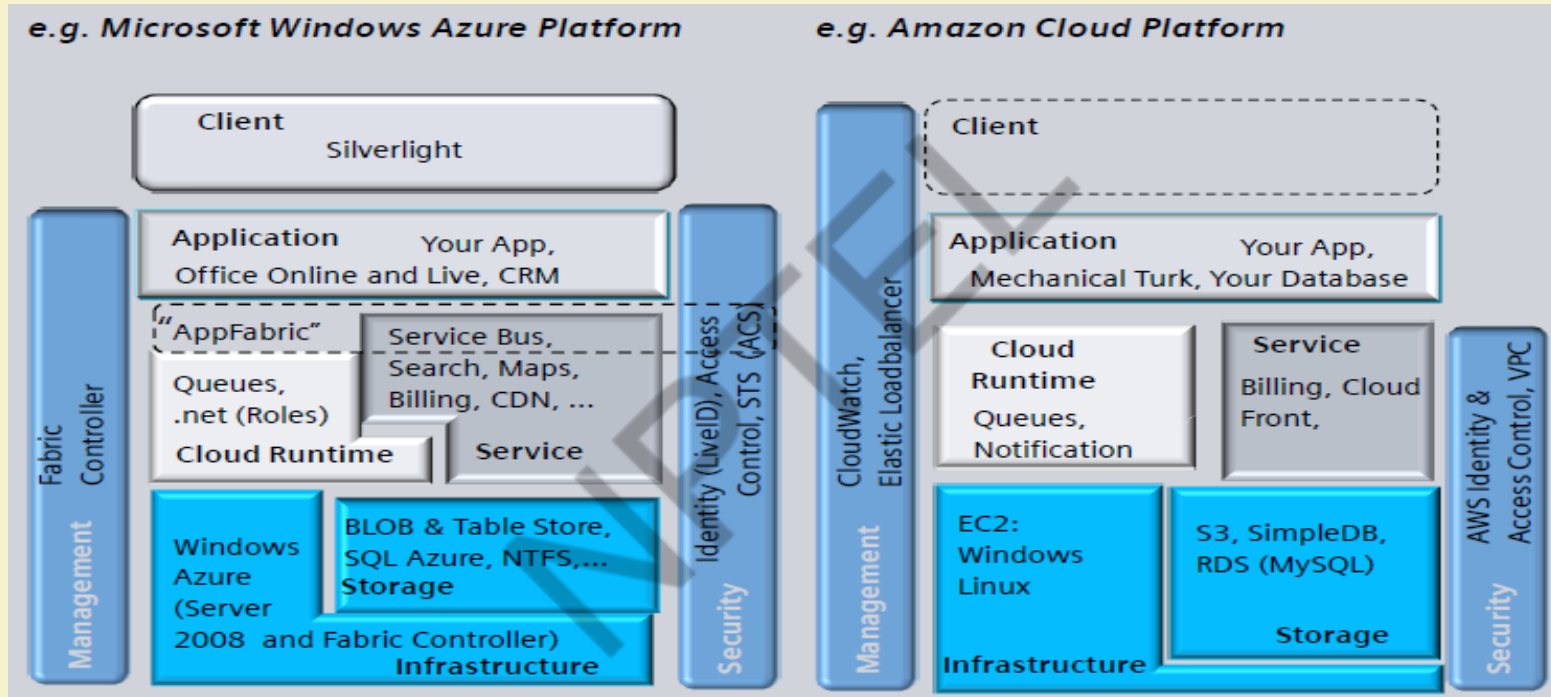

Source: <http://www.sei.cmu.edu/library/assets/presentations/Cloud%20Computing%20Architecture%20-%20Gerald%20Kaefer.pdf>

Architecture for elasticity

Vertical Scale Up

- Add more resources to a single computation unit i.e. Buy a bigger box
- Move a workload to a computation unit with more resources

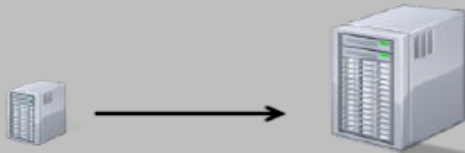

For small scenarios scale up is probably cheaper - code "just works"

Horizontal Scale Out

- Adding additional computation units and having them act in concert
- Splitting workload across multiple computation units
- Database partitioning



For larger scenarios scale out is the only solution
1x64 Way Server much more expensive than
64x1 Way Servers

Source: <http://www.sei.cmu.edu/library/assets/presentations/Cloud%20Computing%20Architecture%20-%20Gerald%20Kaefer.pdf>

Service Models (XaaS)

- Combination of Service-Oriented Infrastructure (SOI) and cloud computing realizes to XaaS.
- X as a Service (XaaS) is a generalization for cloud-related services
- XaaS stands for "anything as a service" or "everything as a service"
- XaaS refers to an increasing number of services that are delivered over the Internet rather than provided locally or on-site
- XaaS is the essence of cloud computing.

Service Models (XaaS)

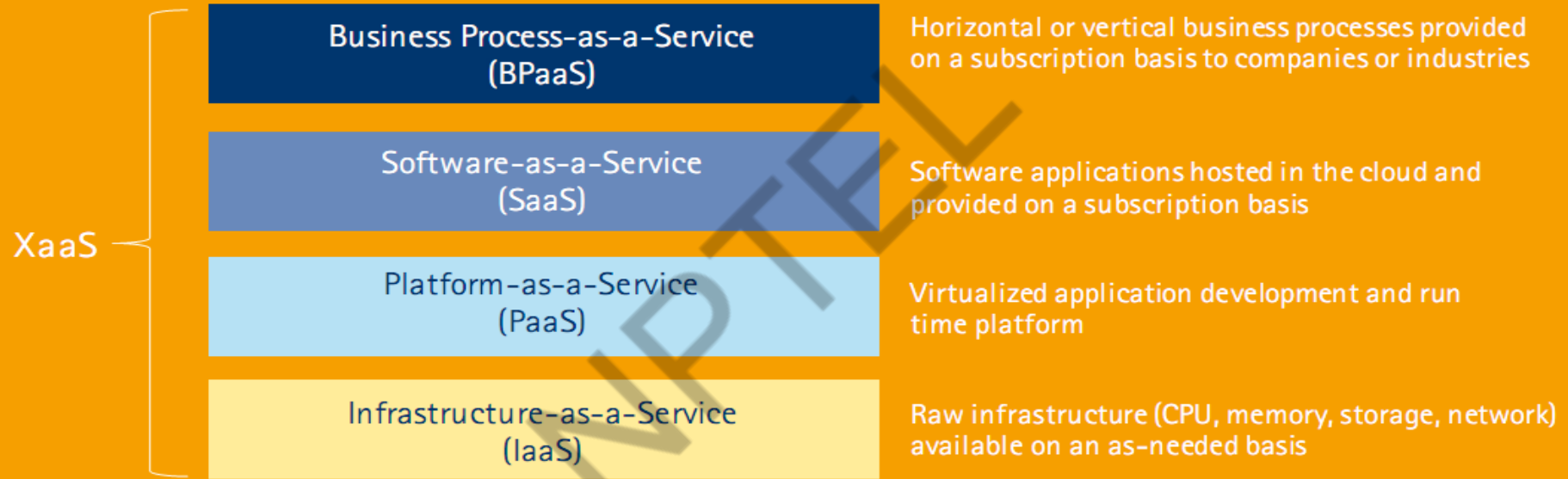

Service Models (XaaS)

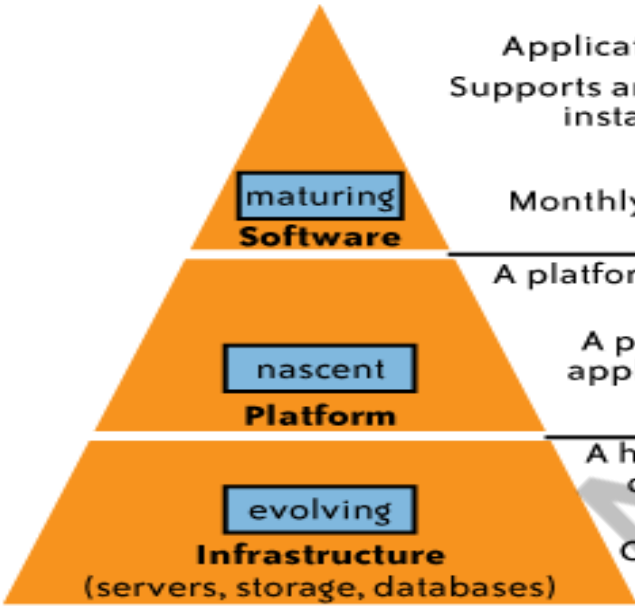
	Definition	Examples
 <p>maturing Software</p>	<p>Applications that are enabled for the cloud Supports an architecture that can run multiple instances of itself regardless of location Stateless application architecture Monthly subscription-based pricing model</p>	<ul style="list-style-type: none"> • Google Docs • MobileMe • Zoho
<p>nascent Platform</p>	<p>A platform that enables developers to write applications that run on the cloud A platform would usually have several application services available for quick deployment</p>	<ul style="list-style-type: none"> • Microsoft Azure • Google App Engine • Force.com
<p>evolving Infrastructure (servers, storage, databases)</p>	<p>A highly scaled redundant and shared computing infrastructure accessible using Internet technologies Consists of servers, storage, security, databases, and other peripherals</p>	<ul style="list-style-type: none"> • Amazon EC2, S3, etc. • Rackspace Mosso offering • Sun's cloud services • Terremark cloud offering

Source: Cloud Security and Privacy: An Enterprise Perspective on Risks and Compliance by Tim Mather and Subra Kumaraswamy

Service Models (XaaS)

- **Most common examples of XaaS are**
 - Software as a Service (SaaS)
 - Platform as a Service (PaaS)
 - Infrastructure as a Service (IaaS)
- **Other examples of XaaS include**
 - Business Process as a Service (BPaaS)
 - Storage as a service (another SaaS)
 - Security as a service (SECaaS)
 - Database as a service (DaaS)
 - Monitoring/management as a service (MaaS)
 - Communications, content and computing as a service (CaaS)
 - Identity as a service (IDaaS)
 - Backup as a service (BaaS)
 - Desktop as a service (DaaS)

Requirements of CSP (Cloud Service Provider)

- Increase productivity
- Increase end user satisfaction
- Increase innovation
- Increase agility

Service Models (XaaS)

- Broad network access (cloud) + resource pooling (cloud) + business-driven infrastructure on-demand (SOI) + service-orientation (SOI) = **XaaS**
- XaaS fulfils all the 4 demands!



Source: Understanding the Cloud Computing Stack: PaaS, SaaS, IaaS © Diversity Limited, 2011

Classical Service Model

- All the Layers(H/W, Operating System, Development Tools, Applications) Managed by the Users
- Initial IT budget and resources.
- Users bears the costs of the hardware, maintenance and technology.
- Each system is designed and funded for a specific business activity: custom build-to-order
- Systems are deployed as a vertical stack of “layers” which are tightly coupled, so no single part can be easily replaced or changed
- Prevalent of manual operations for provisioning, management
- Result: Legacy IT

ADR MOV SSN

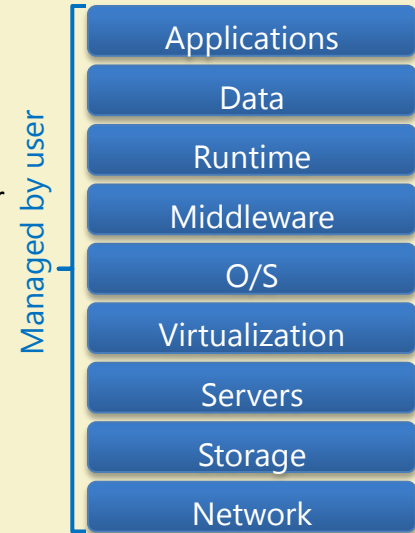

Source: Dragan , “XaaS as a Modern Infrastructure for eGovernment Busines Model in the Republic of Croatia”

Key impact of cloud computing for IT function: From Legacy IT to Evergreen IT

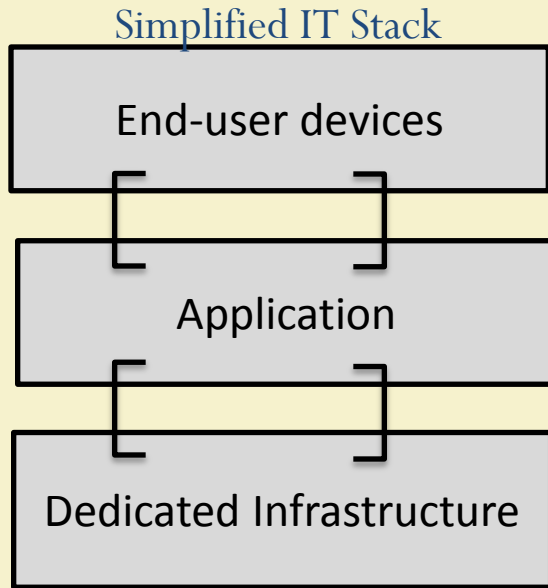

Legacy IT

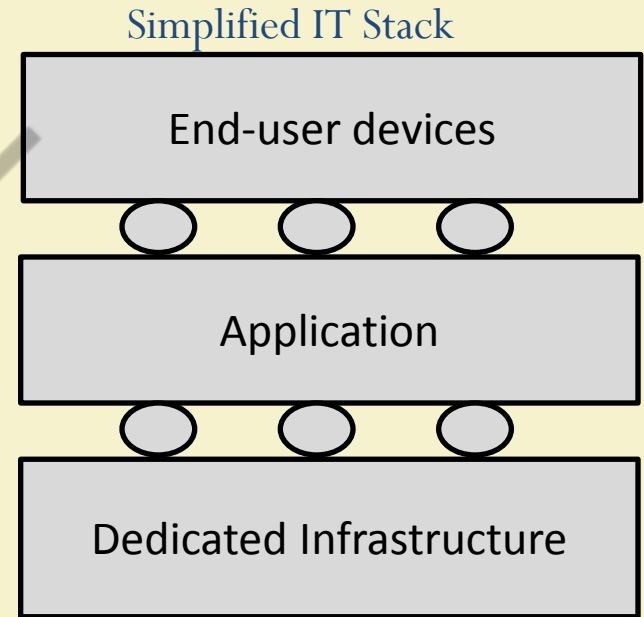
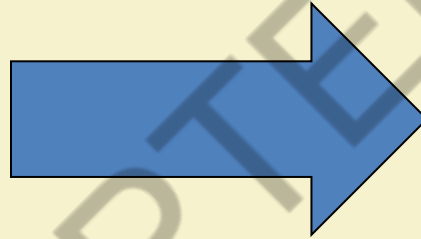

Evergreen IT

Classic Model vs. XaaS

	Business Model	Definition/Example
Traditional	1 Licensed Software	Traditional Software Licenses (w/ upgrade + maintenance) Examples: Oracle; SAP, Microsoft
	2 Hardware Product	Hardware Product sale (e.g. PC, Server, Router) plus maintenance / support services Examples: Cisco, Dell, HP
	3 People-based Services	Professional Services Examples: IBM Global Services, Accenture, Wipro
New/ Emerging	4 SaaS	Software functionality delivered as utility services Examples: Salesforce.com; Taleo; Workday; NetSuite
	5 IaaS	Storage-on-demand, compute capacity Examples: eVault; Amazon EC2; Dropbox
	6 PaaS	Provide entire web services dev. environment/ platform Examples: Force.com; Azure; Amazon Web Services

Client Server Architecture



Source: Wikipedia



IIT KHARAGPUR



NPTEL ONLINE
CERTIFICATION COURSES

Thank You!





IIT KHARAGPUR



NPTEL ONLINE
CERTIFICATION COURSES

CLOUD COMPUTING

CLOUD COMPUTING ARCHITECTURE

PROF. SOUMYA K. GHOSH

DEPARTMENT OF COMPUTER SCIENCE AND ENGINEERING
IIT KHARAGPUR

Client Server Architecture

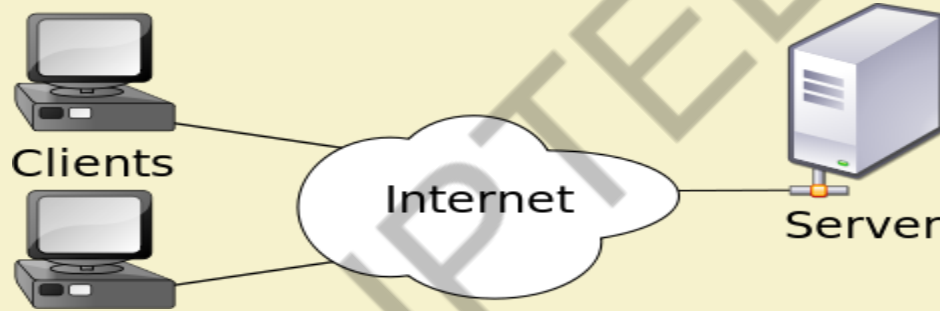

Source: Wikipedia



Client server architecture

- Consists of one or more load balanced servers servicing requests sent by the clients
- Clients and servers exchange message in request-response fashion
- Client is often a thin client or a machine with low computational capabilities
- Server could be a load balanced cluster or a stand alone machine.

Three Tier Client-Server Architecture

Presentation tier

The top-most level of the application is the user interface. The main function of the interface is to translate tasks and results to something the user can understand.

Logic tier

This layer coordinates the application, processes commands, makes logical decisions and evaluations, and performs calculations. It also moves and processes data between the two surrounding layers.

Data tier

Here information is stored and retrieved from a database or file system. The information is then passed back to the logic tier for processing, and then eventually back to the user.

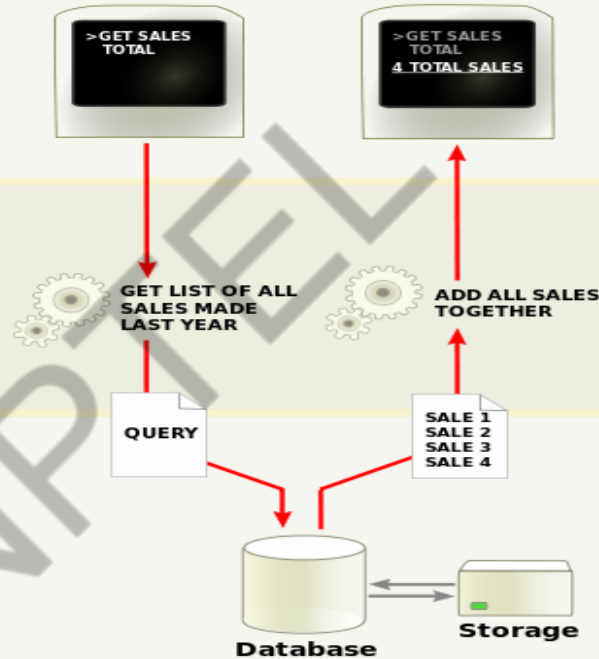

Source: Wikipedia

Client Server model vs. Cloud model

Client server model

- Simple service model where server services client requests
- May/may not be load balanced
- Scalable to some extent in a cluster environment.
- No concept of virtualization

Cloud computing model

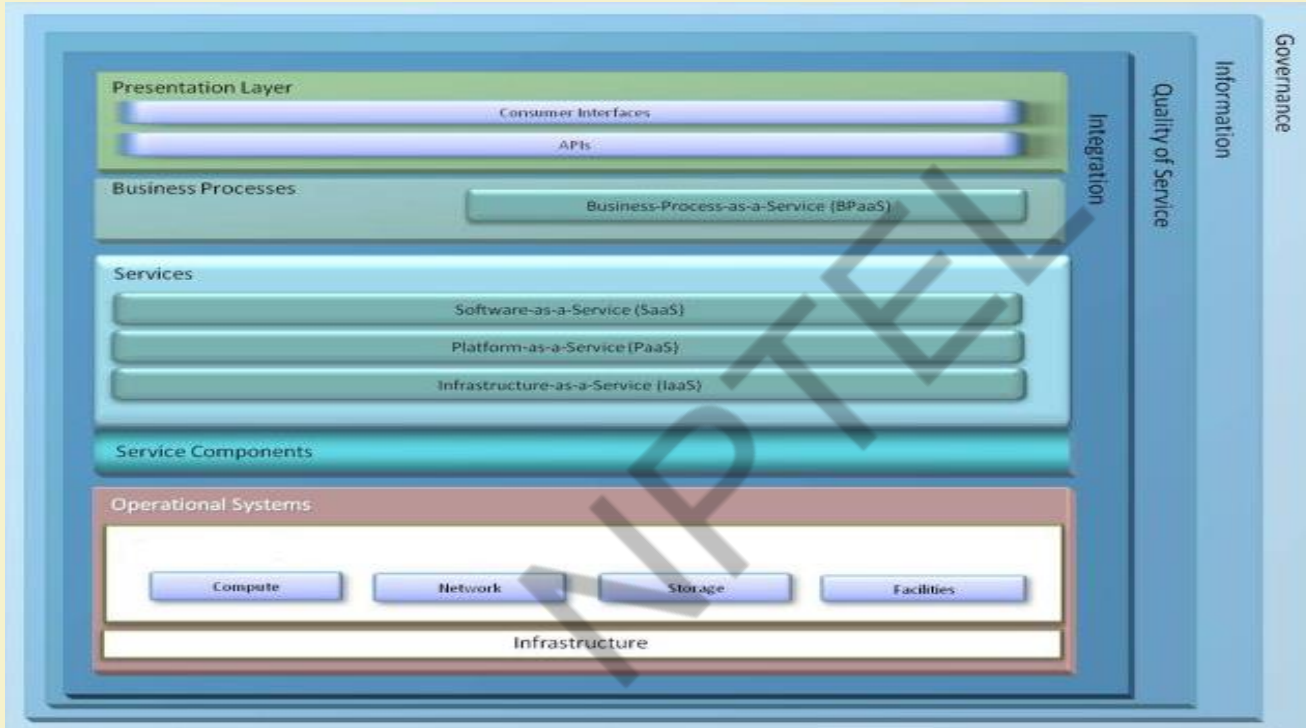

- Variety of complex service models, such as, IaaS, PaaS, SaaS can be provided
- Load balanced
- Theoretically infinitely scalable
- Virtualization is the core concept

Cloud Services



Source : <http://www.opengroup.org/soa/source-book/socci/extend.htm#figure2>

Cloud service models

Service Class	Main Access & Management Tool	Service content
 SaaS	Web Browser	Cloud Applications Social networks, Office suites, CRM, Video processing
 PaaS	Cloud Development Environment	Cloud Platform Programming languages, Frameworks, Mashups editors, Structured data
 IaaS	Virtual Infrastructure Manager	Cloud Infrastructure Compute Servers, Data Storage, Firewall, Load Balancer

Source: <http://www.cs.helsinki.fi/u/epsavola/seminaari/Cloud%20Service%20Models.pdf>

Simplified description of cloud service models

- **SaaS** applications are designed for end users and are delivered over the web
- **PaaS** is the set of tools and services designed to make coding and deploying applications quickly and efficiently
- **IaaS** is the hardware and software that powers it all – servers, storage, network, operating systems

Source: http://broadcast.rackspace.com/hosting_knowledge/whitepapers/Understanding-the-Cloud-Computing-Stack.pdf



Transportation Analogy

- By itself, infrastructure isn't useful – it just sits there waiting for someone to make it productive in solving a particular problem. Imagine the Interstate transportation system in the U.S. Even with all these roads built, they wouldn't be useful without cars and trucks to transport people and goods. In this analogy, the roads are the infrastructure and the cars and trucks are the platform that sits on top of the infrastructure and transports the people and goods. These goods and people might be considered the software and information in the technical realm

Source: http://broadcast.rackspace.com/hosting_knowledge/whitepapers/Understanding-the-Cloud-Computing-Stack.pdf

Software as a Service

- SaaS is defined as software that is deployed over the internet. With SaaS, a provider licenses an application to customers either as a service on demand, through a subscription, in a “pay-as-you-go” model, or (increasingly) at no charge when there is opportunity to generate revenue from streams other than the user, such as from advertisement or user list sales.

Source: http://broadcast.rackspace.com/hosting_knowledge/whitepapers/Understanding-the-Cloud-Computing-Stack.pdf

SaaS characteristics

- Web access to commercial software
- Software is managed from central location
- Software is delivered in a 'one to many' model
- Users not required to handle software upgrades and patches
- Application Programming Interfaces (API) allow for integration between different pieces of software.

Source: http://broadcast.rackspace.com/hosting_knowledge/whitepapers/Understanding-the-Cloud-Computing-Stack.pdf

Applications where SaaS is used

- Applications where there is significant interplay between organization and outside world. E.g. email newsletter campaign software
- Applications that have need for web or mobile access. E.g. mobile sales management software
- Software that is only to be used for a short term need.
- Software where demand spikes significantly. E.g. Tax/Billing softwares. **Put an end**
- E.g. of SaaS: Sales Force Customer Relationship Management (CRM) software

Source: http://broadcast.rackspace.com/hosting_knowledge/whitepapers/Understanding-the-Cloud-Computing-Stack.pdf

Applications where SaaS may not be the best option

- Applications where extremely fast processing of real time data is needed
- Applications where legislation or other regulation does not permit data being hosted externally
- Applications where an existing on-premise solution fulfills all of the organization's needs

Source: http://broadcast.rackspace.com/hosting_knowledge/whitepapers/Understanding-the-Cloud-Computing-Stack.pdf

Platform as a Service

- Platform as a Service (PaaS) brings the benefits that SaaS bought for applications, but over to the software development world. PaaS can be defined as a computing platform that allows the creation of web applications quickly and easily and without the complexity of buying and maintaining the software and infrastructure underneath it.
- PaaS is analogous to SaaS except that, rather than being software delivered over the web, it is a platform for the creation of software, delivered over the web.

Source: http://broadcast.rackspace.com/hosting_knowledge/whitepapers/Understanding-the-Cloud-Computing-Stack.pdf

Characteristics of PaaS

- Services to develop, test, deploy, host and maintain applications in the same integrated development environment. All the varying services needed to fulfill the application development process.
- Web based user interface creation tools help to create, modify, test and deploy different UI scenarios.
- Multi-tenant architecture where multiple concurrent users utilize the same development application.
- Built in scalability of deployed software including load balancing and failover.
- Integration with web services and databases via common standards.
- Support for development team collaboration – some PaaS solutions include project planning and communication tools.
- Tools to handle billing and subscription management

Source: http://broadcast.rackspace.com/hosting_knowledge/whitepapers/Understanding-the-Cloud-Computing-Stack.pdf

Scenarios where PaaS is used

- PaaS is especially useful in any situation where multiple developers will be working on a development project or where other external parties need to interact with the development process
- PaaS is useful where developers wish to automate testing and deployment services.
- The popularity of agile software development, a group of software development methodologies based on iterative and incremental development, will also increase the uptake of PaaS as it eases the difficulties around rapid development and iteration of software.
- PaaS Examples: Microsoft Azure, Google App Engine

Source: http://broadcast.rackspace.com/hosting_knowledge/whitepapers/Understanding-the-Cloud-Computing-Stack.pdf

Scenarios where PaaS is not ideal

- Where the application needs to be highly portable in terms of where it is hosted.
- Where proprietary languages or approaches would impact on the development process
- Where a proprietary language would hinder later moves to another provider – concerns are raised about vendor lock in
- Where application performance requires customization of the underlying hardware and software

Source: http://broadcast.rackspace.com/hosting_knowledge/whitepapers/Understanding-the-Cloud-Computing-Stack.pdf

Infrastructure as a Service

- Infrastructure as a Service (IaaS) is a way of delivering Cloud Computing infrastructure – servers, storage, network and operating systems – as an on-demand service.
- Rather than purchasing servers, software, datacenter space or network equipment, clients instead buy those resources as a fully outsourced service on demand.

Source: http://broadcast.rackspace.com/hosting_knowledge/whitepapers/Understanding-the-Cloud-Computing-Stack.pdf

Characteristics of IaaS

- Resources are distributed as a service
- Allows for dynamic scaling
- Has a variable cost, utility pricing model
- Generally includes multiple users on a single piece of hardware

Source: http://broadcast.rackspace.com/hosting_knowledge/whitepapers/Understanding-the-Cloud-Computing-Stack.pdf

Scenarios where IaaS makes sense

- Where demand is very volatile – any time there are significant spikes and troughs in terms of demand on the infrastructure
- For new organizations without the capital to invest in hardware
- Where the organization is growing rapidly and scaling hardware would be problematic
- Where there is pressure on the organization to limit capital expenditure and to move to operating expenditure
- For specific line of business, trial or temporary infrastructural needs

Source: http://broadcast.rackspace.com/hosting_knowledge/whitepapers/Understanding-the-Cloud-Computing-Stack.pdf

Scenarios where IaaS may not be the best option

- Where regulatory compliance makes the offshoring or outsourcing of data storage and processing difficult
- Where the highest levels of performance are required, and on-premise or dedicated hosted infrastructure has the capacity to meet the organization's needs

Source: http://broadcast.rackspace.com/hosting_knowledge/whitepapers/Understanding-the-Cloud-Computing-Stack.pdf

SaaS providers

Provider	Software	Pricing model
Salesforce.com	CRM	Pay per use
Google Gmail	Email	Free
Process Maker Live	Business process management	Pay per use
XDrive	Storage	Subscription
SmugMug	Data sharing	Subscription
OpSource	Billing	Subscription
Appian Anywhere	Business process management	Pay per use
Box.net	Storage	Pay per use
MuxCloud	Data processing	Pay per use

Source: <http://www.cs.helsinki.fi/u/epsavola/seminaari/Cloud%20Service%20Models.pdf>

Feature comparison of PaaS providers

Provider	Target to Use	Programming language, Frameworks	Programming Models	Persistence options
Aneka	.NET enterprise applications, Web applications	.NET	Threads, Task, MapReduce	Flat files, RDBMS
AppEngine	Web applications	Python, Java	Request-based Web programming	BigTable
Force.com	Enterprise applications	Apex	Workflow, Request-based Web programming, Excel-like formula language	Own object database
Azure	Enterprise applications, Web applications	.NET	Unrestricted	Table/BLOB/queue storage, SQL Services
Heroku	Web applications	Ruby on Rails	Request-based Web programming	PostgreSQL, Amazon RDS
Amazon Elastic MapReduce	Data processing	Hive and Pig, Cascading, Java, Ruby, Perl, Python, PHP, C++	MapReduce	Amazon S3

Source: <http://www.cs.helsinki.fi/u/epsavola/seminaari/Cloud%20Service%20Models.pdf>

Feature comparison of IaaS providers

Provider	Geographic distribution of data centers	User interfaces and APIs	Hardware capacity	Guest operating systems	Smallest billing unit
Amazon E2C	US Europe	CLI, WS, Portal	CPU: 1_20 EC2 compute units Memory: 1.7-15 GB Storage: 160-1690 GB, 1 GB – 1 TB (per ESB units)	Linux Windows	Hour
Flexiscale	UK	Web console	CPU: 1-4 Memory: 0.5-16 GB Storage: 20-270 GB	Linux, Windows	Hour
GoGrid		REST, Java, PHP, Python, Ruby	CPU: 1-6 Memory: 0.5-8 GB Storage: 30-480 GB	Linux, Windows	Hour
Joyent	US		CPU: 1/16-8 Memory: 0.25-32.5 GB Storage: 5-100GB	OpenSolaris	Month
RackSpace	US	Portal, REST, Python, PHP, Java, .NET	CPU: Quad-core Memory: 0.25-16 GB Storage: 10-620 GB	Linux	Hour

Source: <http://www.cs.helsinki.fi/u/epsavola/seminaari/Cloud%20Service%20Models.pdf>



XaaS

SaaS

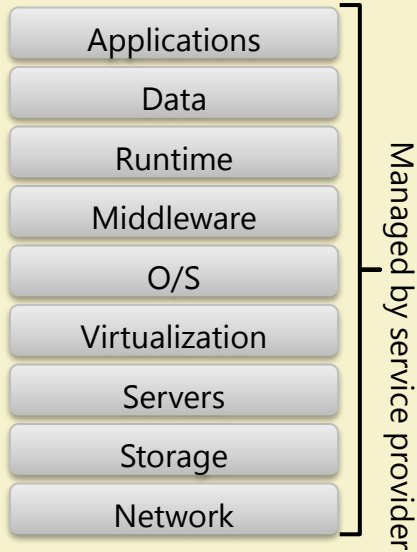

ADR MOV SSN

PaaS

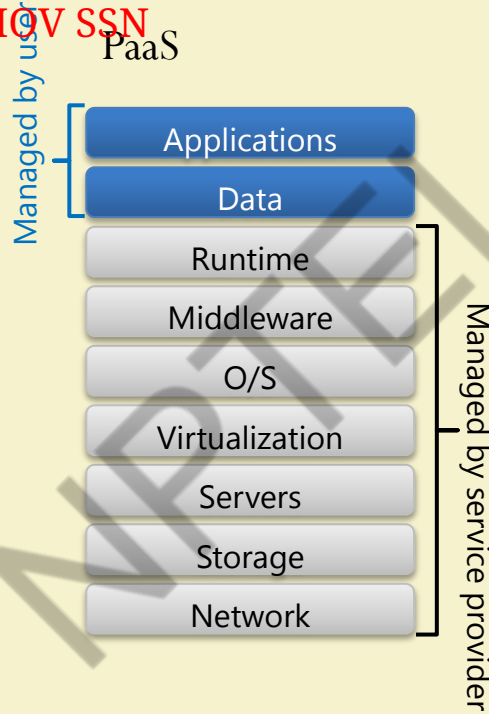

IaaS

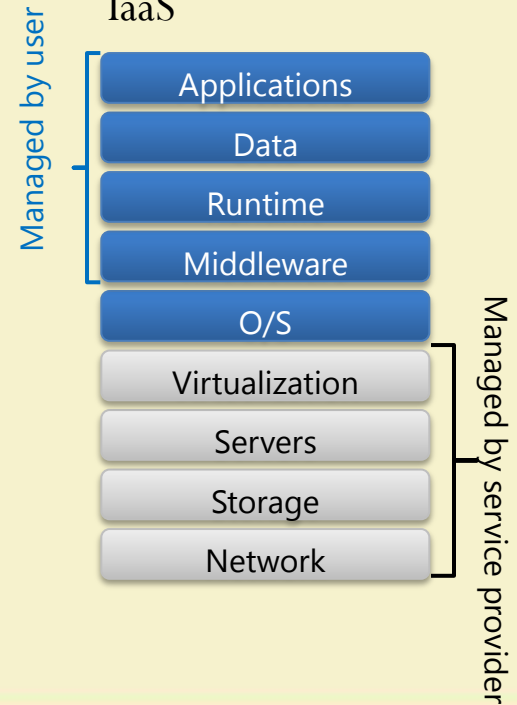

Role of Networking in cloud computing

- In cloud computing, network resources can be provisioned dynamically.
- Some of the networking concepts that form the core of cloud computing are Virtual Local Area Networks, Virtual Private Networks and the different protocol layers.
- Examples of tools that help in setting up different network topologies and facilitate various network configurations are OpenSSH, OpenVPN etc.

Source: <http://www.slideshare.net/alexamies/networking-concepts-and-tools-for-the-cloud>

Networking in different cloud models

OSI Layer	Example Protocols	IaaS	PaaS	SaaS
7 Application	HTTP, FTP, NFS, SMTP, SSH	Consumer	Consumer	Provider
6 Presentation	SSL, TLS	Consumer	Provider	Provider
5 Session	TCP	Consumer	Provider	Provider
4 Transport	TCP	Consumer	Provider	Provider
3 Network	IP, IPsec	Consumer	Provider	Provider
2 Data Link	Ethernet, Fibre channel	Provider	Provider	Provider
1 Physical	Copper, optic fibre	Provider	Provider	Provider

Source: <http://www.slideshare.net/alexamies/networking-concepts-and-tools-for-the-cloud>



Network Function Virtualization

Definition: “Network Functions Virtualisation aims to transform the way that network operators architect networks by evolving standard IT virtualisation technology to consolidate many network equipment types onto industry standard high volume servers, switches and storage, which could be located in Datacentres, Network Nodes and in the end user premises, as illustrated in Figure 1. It involves the implementation of network functions in software that can run on a range of industry standard server hardware, and that can be moved to, or instantiated in, various locations in the network as required, without the need for installation of new equipment.”

Source: https://portal.etsi.org/nfv/nfv_white_paper.pdf

Network Function Virtualization

Classical Network Appliance Approach



- Fragmented non-commodity hardware.
- Physical install per appliance per site.
- Hardware development large barrier to entry for new vendors, constraining innovation & competition.



Source: https://portal.etsi.org/nfv/nfv_white_paper.pdf



Thank You!!

